

SH11263
REV 1
ON DWG

D

C

B

A

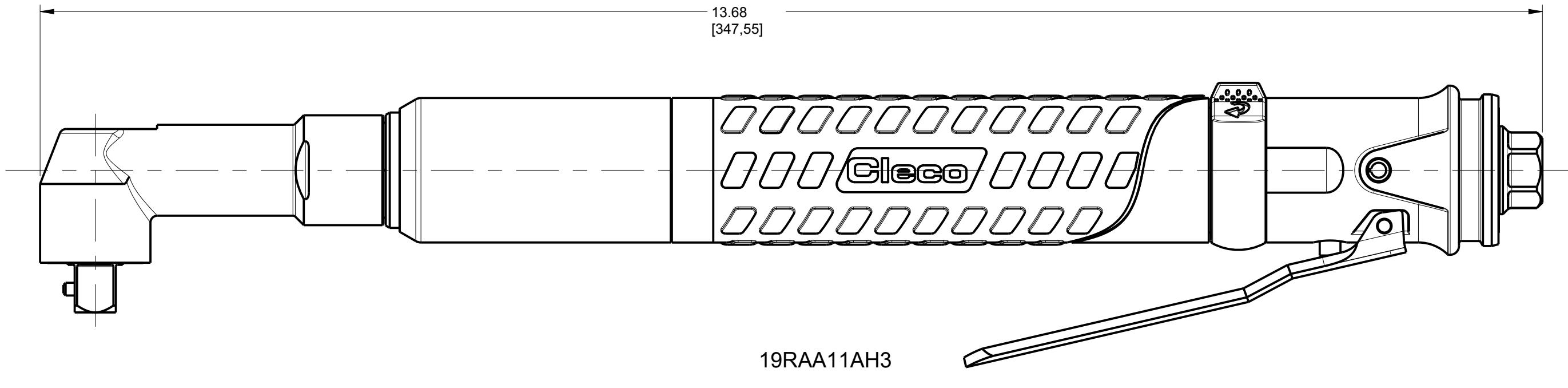
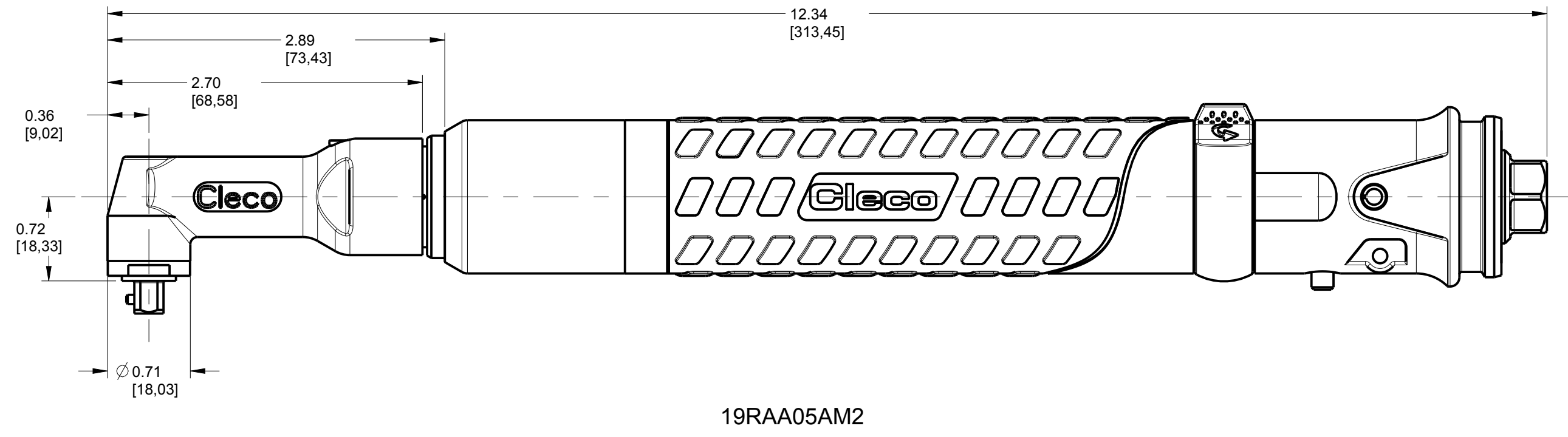
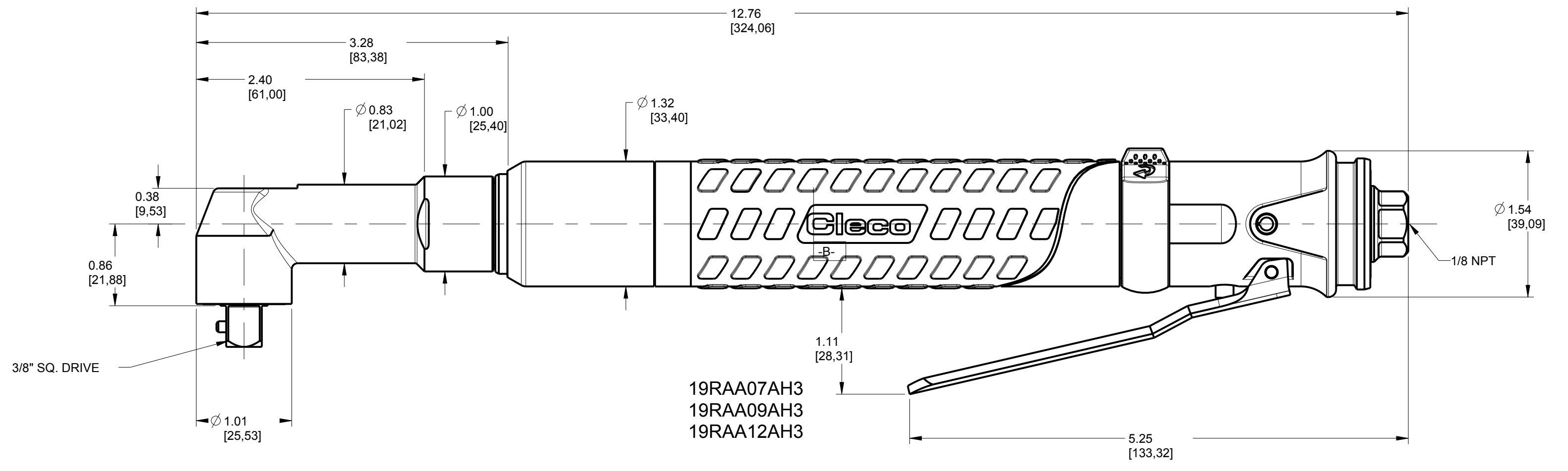
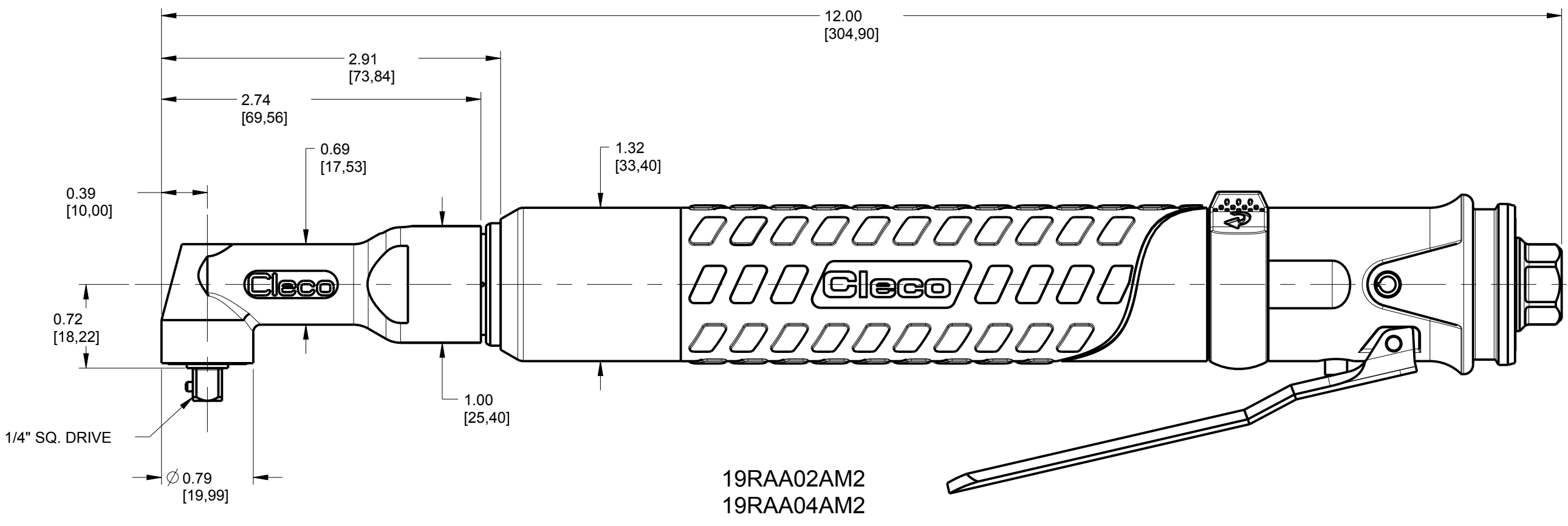

NOTE:
 PRIMARY DIMENSIONS ARE IN INCHES
 SECONDARY DIMENSIONS IN BRACKETS [] ARE METRIC AND ARE REFERENCE ONLY

This document contains confidential and trade secret information which is the property of Apex Tool Group and receipt or possession does not convey any rights to loan, sell, or otherwise disclose said information. Reproduction or use of said information for any purpose other than that in connection with which said information was supplied may not be made without express written permissions of Apex Tool Group. This document is to be returned to Apex Tool Group upon request and in all events upon completion of the purpose for which it is loaned.

UNLESS OTHERWISE SPECIFIED: TWO PLACE DECIMALS ± .01, THREE PLACE DECIMALS ± .005, FOUR PLACE DECIMALS ± .0005		MACHINE SURFACES: GEOMETRIC SYMBOLS PER ANSI Y14.5, MACHINE FILLETS: .015 MAX, BREAK SHARP EDGES: .015 MAX		ANGULAR SURFACES TO BE TRUE WITHIN ± 1°, FEATURES ON COMMON TO BE CONCENTRIC WITHIN .010 TOTAL	
ZONEREV	REVISION	DATE	BY		
MATERIAL			DESCRIPTION		
ASM			OUTLINE DRAWING		
HEAT TREAT			19RAA SERIES		
HARDNESS			NUTRUNNER		
FINISH			DRAWN BY	DATE	ENG APP
SIMILAR TO			REH	2/01/12	R HOUSE
SCALE			DWG SIZE	SHEET	REV DATE
1:1			D	1 OF 1	7/12/12
PART NO			DRAWING NO		
SEE DRAWING			SH11263		