

**Cleco**<sup>®</sup>  
Production Tools

Programming Manual  
P2544PM-EN  
2022-12 | REV H

**CellTek**<sup>™</sup>

**S169263**

CTBA & CTBP



For additional product information visit our website at [www.ClecoTools.com](http://www.ClecoTools.com)

Copyright © Apex Tool Group, 2022

No part of this document may be reproduced in any way or in any form, in whole or in part, or in a natural or machine-readable language, or transmitted on electronic, mechanical, optical, or other media, without the express permission of the Apex Tool Group.

### **Disclaimer**

Apex Tool Group reserves the right to modify, supplement, or improve this document or the product without prior notice.

### **Trademark**

Cleco Production Tools is a registered trademark of Apex Brands, Inc.

### **Apex Tool Group**

670 Industrial Drive  
Lexington, SC 29072  
USA

Manufacturer

### **Apex Tool Group GmbH**

Industriestraße 1  
73463 Westhausen  
Germany

# Content

<b>1</b>	<b>About this document .....</b>	<b>5</b>
<b>2</b>	<b>Product Description .....</b>	<b>7</b>
2.1	Confirmation button .....	7
2.2	Navigation buttons .....	7
2.3	USB connection .....	8
2.4	Insert the CID.....	9
2.5	System Layout .....	10
2.5.1	WLAN communication .....	10
2.5.2	Bluetooth communication .....	13
<b>3</b>	<b>Before Initial Operation.....</b>	<b>14</b>
3.1	Requirements .....	14
3.2	Install Software .....	14
3.3	Install driver.....	14
<b>4</b>	<b>Initial operation.....</b>	<b>15</b>
4.1	Configuring the access point .....	15
4.1.1	mPro200GC-AP .....	15
4.1.2	mPro400GCD .....	16
4.2	Configuring RF settings .....	17
4.3	Installing the Tool.....	19
<b>5</b>	<b>Menus And Functions .....</b>	<b>20</b>
5.1	General Functions .....	20
5.1.1	Switching On The Tool .....	20
5.1.2	Switching Off Tool.....	20
5.1.3	Selecting a button .....	20
5.1.4	Changing parameters .....	20
5.1.5	Change between FastApps and mPro mode.....	21
5.2	CID (CellTek ID Card).....	21
5.3	Display .....	21
5.4	Menu structure overview.....	23
5.5	Run screen.....	24
5.5.1	Selecting the FastApps.....	25
5.5.2	Selecting the Application/Linking group.....	25
5.5.3	Status Indication .....	25
5.5.4	Counterclockwise rotation.....	26
5.6	Main menu .....	26
5.7	FastApps menu.....	27
5.7.1	Configuring FastApps .....	28
5.7.2	Selecting the direction of rotation .....	30
5.7.3	Selecting the tightening strategy .....	31
5.7.4	Advanced Settings.....	31
5.7.5	Resetting FastApp .....	32

5.8	Settings .....	33
5.8.1	Setting the date and time .....	34
5.8.2	Adjusting the screen brightness .....	34
5.8.3	Adjusting the tool light.....	35
5.8.4	Setting the shut-off properties.....	36
5.8.5	Selecting the torque units .....	36
5.8.6	Setting the PIN.....	37
5.8.7	Locking a menu .....	39
5.8.8	Allowing a Linking group/FastApp selection .....	39
5.9	Diagnostics .....	39
5.9.1	Speed test.....	41
5.9.2	Angle test.....	41
5.9.3	Torque test.....	42
5.9.4	Calibration value .....	43
5.9.5	Voltage.....	43
5.9.6	Counters status.....	44
5.9.7	Maintenance Counter .....	44
5.9.8	Torque calibration value .....	45
5.9.9	Accessory .....	45
5.10	WLAN communication .....	46
5.10.1	Activating/deactivating WLAN connection .....	48
5.10.2	Installing EAP-TLS certificate .....	48
5.11	Bluetooth communication .....	49
5.11.1	Activating/deactivating Bluetooth.....	50
5.11.2	Scanning Bluetooth devices .....	51
5.11.3	Disconnect Bluetooth connection .....	51
5.12	Utility .....	52
5.12.1	Displaying the software version.....	52
5.12.2	Carry Out a Software Update .....	53
5.12.3	Resetting to factory settings .....	54
<b>6</b>	<b>Tightening sequence .....</b>	<b>55</b>
<b>7</b>	<b>Troubleshooting .....</b>	<b>57</b>
7.1	Messages on the Display.....	57
7.2	Error messages .....	58
7.3	Tool problems .....	60
7.4	WLAN data communication problems .....	61
7.5	Bluetooth data communication problems .....	62

# 1 About this document

This document is intended for qualified employees responsible for installation and maintenance (administrators, maintenance technician, service, operator).

It contains information

- for safe and appropriate handling of the product.
- on function.
- for programming the software: S169263-222

The original language of this document is German.

## Other documents

Number	Document
P1730PM	Programming Manual – Tightening Sequences
P2280PM	Programming Manual – S168813 mPro400GC(D) & mPro200GC(-AP)
P2372JH	Installation Instruction – S168688 LiveWire Utilities
P2381TS	Troubleshooting – EMS Error messages
P2403HW	Hardware Description – mPro200GC(-AP)
P2521JH	Installation Instructions – S168709 LiveWire Cert
P2543BA	Instruction Manual – CTBA & CTBP
P2545KA	Quick Installation Guide – CTBA & CTBP Data Transmission





## Symbols in the text

<i>italic</i>	Menu options (e.g., Diagnostics) input fields, check boxes, radio buttons or dropdown menus.
>	Indicates selection of a menu option from a menu, e.g., <i>File &gt; Print</i> .
<...>	Specifies switches, pushbuttons or the keys of an external keyboard, e.g., <F5>.
<i>Courier</i>	Indicates Filenames and paths, e.g., <i>setup.exe</i> .
•	Indicates lists, level 1.
–	Indicates lists, level 2.
a) b)	Indicates options.
➤	Indicates results.
1. (...) 2. (...)	Indicates action steps.
▶	Indicates single action steps.

## Other documents

### Warning notes are identified by a signal word and a pictogram:

- The signal word describes the severity and probability of the impending danger.
- The pictogram describes the type of danger.

	<p><b>⚠ Danger</b></p> <p>A symbol combined with the word Danger indicates a hazard with a high level of risk which, if not avoided, will result in death or serious injury.</p>
	<p><b>⚠ Warning</b></p> <p>A symbol combined with the word Warning indicates a hazard with a medium level of risk which, if not avoided, could result in death or serious injury.</p>
	<p><b>⚠ Caution</b></p> <p>A symbol combined with the word Caution indicates a hazard with a low level of risk which, if not avoided, could result in minor or moderate injury.</p>
	<p><b>Note</b></p> <p>A symbol combined with the word Note indicates a potentially harmful situation which, if not avoided, could result in damage to property or the environment.</p>
	<p>General instructions include application tips and useful information, but no warnings against hazards.</p>

## Structure Of Warnings

	<p><b>⚠ Caution</b></p> <p><b>Type and source of danger.</b> Possible consequences of non-observance.</p> <p>▶ Measures to avoid danger.</p>
---	--

## Abbreviations

Abbreviations	Description
OK	Result is OK. The result is within the target value tolerances.
TQ	Torque
NOK	Result is not in order. The result is outside the target value tolerances.
App	Application
AN	Angle

## 2 Product Description

The cordless tool can be used in two modes of operation:

- In the FastApps mode, the tool works independently without a controller. The Linking groups (FastApps) and settings are parameterized on the tool.
- In the mPro mode, a connection between the tool and the controller is necessary. The linking group and settings are parameterized on the controller and sent to the tool.

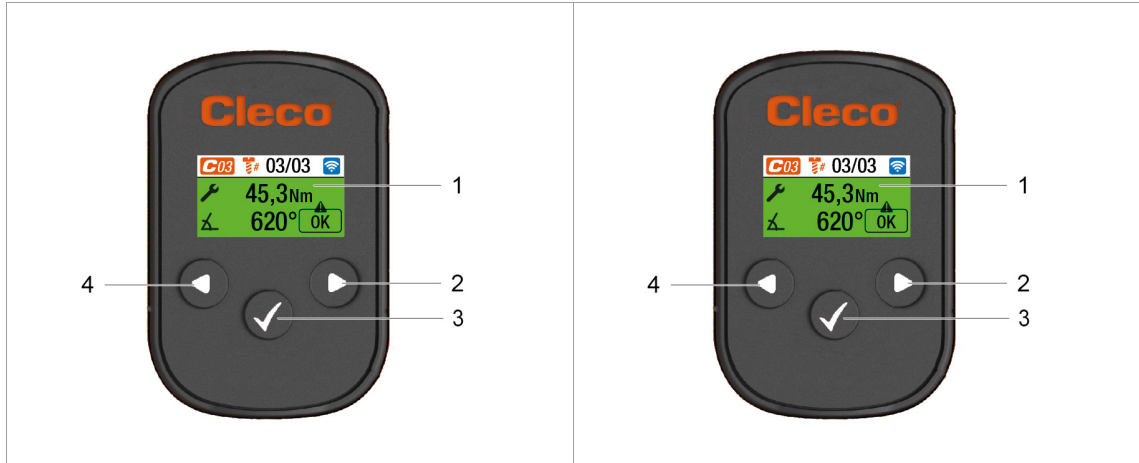

Fig. 2-1: LCD and tool controls from CTBA

Fig. 2-2: LCD and tool controls from CTBA

Item	Description
1	Display
2	Navigation button right
3	Confirmation button
4	Navigation button left



The following description shows the operating elements of the CTBA tools.

### 2.1 Confirmation button

Button	Function
	<ul style="list-style-type: none"> <li>• Open menu.</li> <li>• Confirm settings: The changes are saved.</li> <li>• Activate parameter to change the value.</li> </ul>

### 2.2 Navigation buttons

Use the navigation buttons to navigate to menu items and settings. Some buttons also have additional functions.

Button	Function
	<ul style="list-style-type: none"> <li>• Press to move the selection box to the right.</li> <li>• Press to increase a value.</li> </ul>

Button	Function
	<ul style="list-style-type: none"> <li>• Press to move the selection box to the left.</li> <li>• Press and hold to go to the run screen in the main menu.</li> <li>• Press and hold to jump up one menu level.</li> <li>• Press and hold to exit settings.</li> <li>• Press to decrease a value.</li> </ul>
Start trigger	<ul style="list-style-type: none"> <li>• Press to go directly to the run screen from all menu levels.</li> <li>• Press to start the rundown in the run screen.</li> </ul>

## 2.3 USB connection

Connection for a Micro B USB cable to connect the tool to an external device interface.

This is used for programming WLAN settings.

To connect the Micro B USB cable:





## 2.4 Insert the CID



### Note

#### Damage to the CID

If the CID is inserted incorrectly or not completely, it may be damaged.

- ▶ Insert the CID correctly. Make sure that the CID engages when inserted.

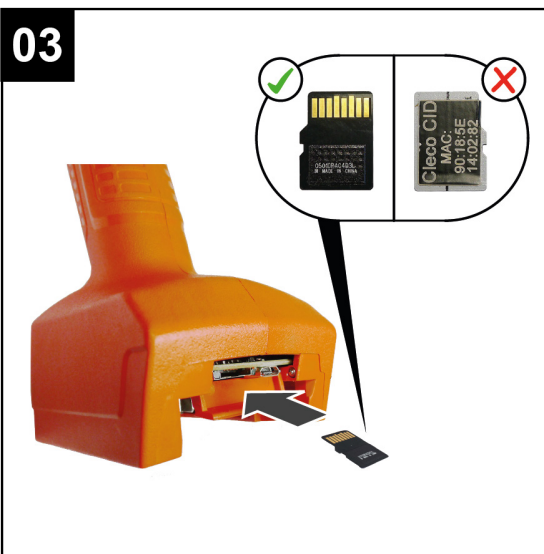
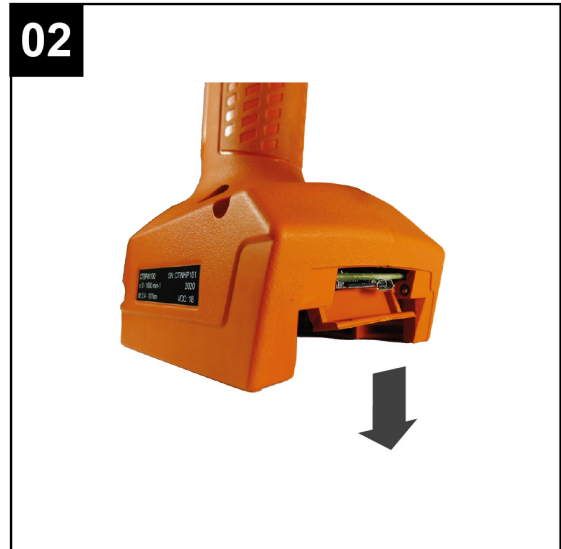

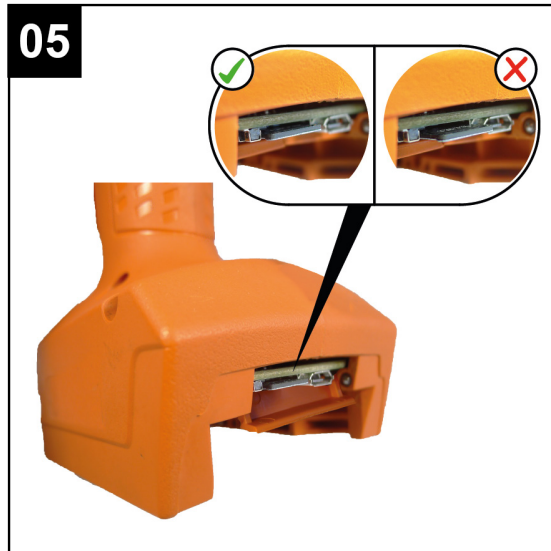

To change the CID:

- ▶ Press the CID slightly inward and release.
  - The CID is unlocked and can be removed.

## 2.5 System Layout

The communication between the controller and the tool is possible via WLAN or Bluetooth. The tool can communicate with a mPro200GC-AP or mPro400GCD controller.

To communicate with the controller, the tools must be in the mPro mode.

### 2.5.1 WLAN communication

The system layout described is based on communication via WLAN. The access point is integrated in the mPro200GC-AP controller. The tools can communicate according to the following standard:

Tool	Standard
CTBA & CTBP	WLAN Dual band: 2,4 GHz/5 GHz Standard IEEE 802.11 a/b/g/n



Fig. 2-3: System layout with mPro200GC-AP

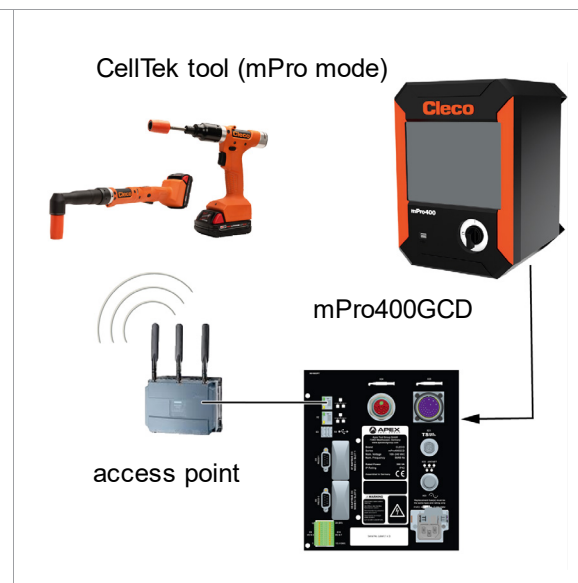

Fig. 2-4: System layout with mPro400GCD

**2.5.1.1 Tool Data**

Feature	Data																						
Standard	IEEE 802.11a/b/g/n																						
Safety	<table border="0"> <tr> <td>WEP-64 HEX</td> <td>802.1x LEAP-TLS TKIP</td> </tr> <tr> <td>WEP-64 ASCII</td> <td>802.1x LEAP-TLS AES</td> </tr> <tr> <td>WEP-128 HEX</td> <td>802.1x EAP-TLS WEP-64</td> </tr> <tr> <td>WEP-128 ASCII</td> <td>802.1x EAP-TLS WEP-128</td> </tr> <tr> <td>WPA/WPA2-PSK TKIP</td> <td>802.1x EAP-TLS TKIP</td> </tr> <tr> <td>WPA/WPA2-PSK AES</td> <td>802.1x EAP-TLS AES</td> </tr> <tr> <td>WPA3-SAE<sup>1</sup></td> <td>Ciso LEAP WEP-64</td> </tr> <tr> <td>WPA3-PEAP<sup>1</sup></td> <td>Ciso LEAP WEP-128</td> </tr> <tr> <td>WPA3-TLS<sup>1</sup></td> <td>Ciso LEAP TKIP</td> </tr> <tr> <td>802.1x LEAP-TLS WEP-64</td> <td>Ciso LEAP AES</td> </tr> <tr> <td>802.1x LEAP-TLS WEP-128</td> <td></td> </tr> </table>	WEP-64 HEX	802.1x LEAP-TLS TKIP	WEP-64 ASCII	802.1x LEAP-TLS AES	WEP-128 HEX	802.1x EAP-TLS WEP-64	WEP-128 ASCII	802.1x EAP-TLS WEP-128	WPA/WPA2-PSK TKIP	802.1x EAP-TLS TKIP	WPA/WPA2-PSK AES	802.1x EAP-TLS AES	WPA3-SAE <sup>1</sup>	Ciso LEAP WEP-64	WPA3-PEAP <sup>1</sup>	Ciso LEAP WEP-128	WPA3-TLS <sup>1</sup>	Ciso LEAP TKIP	802.1x LEAP-TLS WEP-64	Ciso LEAP AES	802.1x LEAP-TLS WEP-128	
WEP-64 HEX	802.1x LEAP-TLS TKIP																						
WEP-64 ASCII	802.1x LEAP-TLS AES																						
WEP-128 HEX	802.1x EAP-TLS WEP-64																						
WEP-128 ASCII	802.1x EAP-TLS WEP-128																						
WPA/WPA2-PSK TKIP	802.1x EAP-TLS TKIP																						
WPA/WPA2-PSK AES	802.1x EAP-TLS AES																						
WPA3-SAE <sup>1</sup>	Ciso LEAP WEP-64																						
WPA3-PEAP <sup>1</sup>	Ciso LEAP WEP-128																						
WPA3-TLS <sup>1</sup>	Ciso LEAP TKIP																						
802.1x LEAP-TLS WEP-64	Ciso LEAP AES																						
802.1x LEAP-TLS WEP-128																							
Range	Typically, up to 100 m																						
Channels	1 – 13 (2,412 – 2,472 GHz) 36, 40, 44, 48, 52, 56, 60, 64, 100, 104, 108, 112, 116, 120, 124, 128, 132, 136, 140, 149, 153, 157, 161, 165 (5,180 – 5,825 GHz)																						
Transmission power	20 dBm																						
Sensitivity	-95 dBm (typ. @ 1 Mbps DSSS, 2.4 GHz) -66.3 dBm (typ. @ 40 MHz MCS7 MM 4K) -92.5 dBm (typ. @ 6 Mbps OFDM, 5 GHz) -69.3 dBm (typ. @ 40 MHz MCS7 MM 4K, 5 GHz)																						
Modulation	CCK/DSSS/OFDM																						
802.11ac/n Spatial Streams	2 (2x2 MIMO)																						
Bluetooth Data Rates Supported	1, 2, 3 Mbps																						
Bluetooth Modulation	GFSK@ 1 Mbps Pi/4-DQPSK@ 2 Mbps 8-DPSK@ 3 Mbps																						

**2.5.1.2 Country-specific channel settings**

The tools work in the license-free 2.4 GHz/5 GHz ISM band.

Band	Channel	Frequency in GHz	World	Europe	USA/Canada
			World	CE	FCC
2.4 GHz IEEE802.11b/g	1	2.412	x	x	x
	2	2.417	x	x	x
	3	2.422	x	x	x
	4	2.427	x	x	x
	5	2.432	x	x	x
	6	2.437	x	x	x
	7	2.442	x	x	x
	8	2.447	x	x	x
	9	2.452	x	x	x
	10	2.457	x	x	x
	11	2.462	x	x	x
	12	2.467	–	x	–

<sup>1</sup> Applies only to CellTek tools with hardware version 2

Band	Channel	Frequency in GHz	World	Europe	USA/Canada
			World	CE	FCC
5 GHz IEEE802.11a U-NII-1	13	2.472	–	x	–
	36	5.180	x	x	x
	40	5.200	x	x	x
	44	5.220	x	x	x
	48	5.240	x	x	x
5 GHz IEEE802.11a U-NII-2	52	5.260	–	x	x
	56	5.280	–	x	x
	60	5.300	–	x	x
	64	5.320	–	x	x
5 GHz IEEE802.11a U-NII-2 ext	100	5.500	–	x	x
	104	5.520	–	x	x
	108	5.540	–	x	x
	112	5.560	–	x	x
	116	5.580	–	x	x
	120	5.600	–	x	–
	124	5.620	–	x	–
	128	5.640	–	x	–
	132	5.660	–	x	–
	136	5.680	–	x	x
	140	5.700	–	x	x

### Legend

x: Approved and available

-: Not permissible, blocking necessary

o: Permissible with limited power to 20 dBm (SRD)

### 2.5.1.3 Cell planning for access point

Each channel operates with a frequency range of 22 MHz. To avoid overlapping the frequency ranges, the channels must be chosen so that they do not overlap. In other words, a maximum of 3 independent channels (e.g., 1, 6 and 11) are available in the 2.4 GHz frequency band.

The 5 GHz frequency band provides up to 21 independent channels.

To minimize interference between different radio cells that share the same RF channel, it is advisable to physically separate them. Note that for multistory buildings, it is necessary to consider both higher and lower floors.

The following overview shows the basic channel assignment.

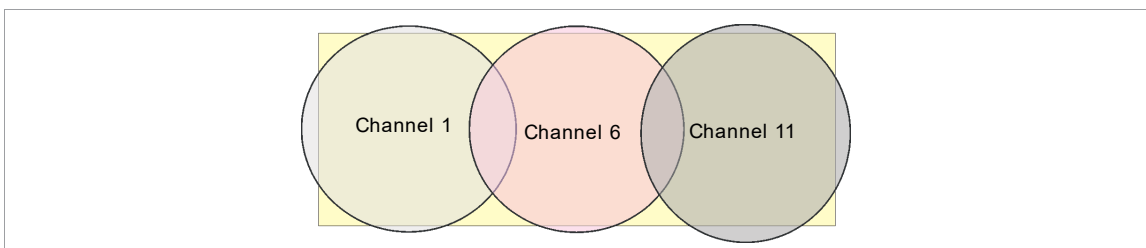

Fig. 2-5: Idealized radio cells, the rectangle symbolize the application areas of the tools

The physical circumference of a radio cell depends primarily on the access point used, the antennas and the type of construction in the surrounding area. The limit of a radio cell is reached when the signal-to-

noise ratio (SNR) falls below 15 dB. If the ratio falls below this value, a new radio cell should be started. The typical circumference of a radio cell in a building is up to 50 m. For the tool to be able to connect to different access points automatically (roaming), the SSID and encryption must be set identically at the corresponding access points.



If wide-area coverage with controlled emission from multiple access points is required, corresponding planning and evaluation must be carried out for the specific case.

**Example installation 5 GHz**

- Several overlapping radio cells are possible, even if only one free channel is used.
- Up to 200 tools are then possible within the radio range with a limited volume of data.
- The range of the radio cells is limited by the minimal transmission power.

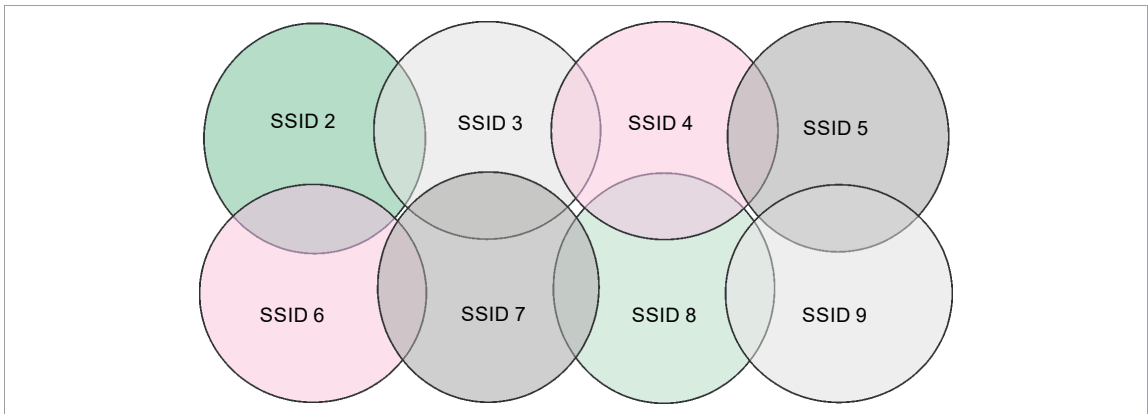

Fig. 2-6: Idealized radio cells = Range of use of the tools, channel 60

**2.5.2 Bluetooth communication**

Tool	Standard
CTBA & CTBP	Bluetooth 4.2

## 3 Before Initial Operation

### 3.1 Requirements

To set up the controller, the following items are required:

- Laptop/PC
- Ethernet cable
- Software *S168691 mProRemote Professional*
- Software *S168688 LiveWire Utilities*
- Monitor with VGA connector, keyboard and mouse (optional)
- Micro B USB cable

### 3.2 Install Software

1. Download the *mProRemote Professional* and *LiveWire Utilities* Software from the following website: <http://software.apextoolgroup.com/current-software-packages/pc-software/>
2. Install the *mProRemote Professional* software on the PC, see Document *S168691 mProRemote Professional*.
3. Install the *S168688 LiveWire Utilities* on the PC, see Document *P2372JH*.
4. Install the tool driver.
5. Set network settings from laptop/PC to i. e. 192.168.100.201 (if mPro200GC-AP is used).

### 3.3 Install driver

To be able to configure the tool via the PC software, the tool driver must be installed.

#### Install tool driver

1. Download the tool driver *cellcore-celltek-usb-driver.zip* from the following website and unpack it: <https://software.apextoolgroup.com/current-software-packages/celltek/>
2. Connect the tool to the PC via a Micro B USB cable.
  - The tool switches on automatically.
3. Open the device manager on the laptop/PC.

## 4 Initial operation

### 4.1 Configuring the access point

#### 4.1.1 mPro200GC-AP

In the factory setting, the IP address and the subnet mask of the controller are specified with a default value (Ethernet 1):

Parameter	Default value
IP address	192.168.100.200
Subnet mask	255.255.255.0



#### Note

##### IP address conflict

The 200 Series controllers have a factory default IP address of 192.168.100.200. If multiple controllers are connected to the same network without changing the original IP address, an IP conflict occurs.

- ▶ Assign a new, unique IP address to each controller.

#### Configuring the access point

1. Connect laptop/PC directly to the controller via an Ethernet cable.
2. Start *mProRemote Professional* on the Laptop/PC.
3. Enter the IP address 192.168.100.200 in the *Remote Control* tab in the *Target* input field.
4. Press *Remote (TCP/IP)*.
  - A connection to the controller is established.
  - The user interface of the controller opens on the laptop/PC.
5. Select *Navigators > Utility > System Settings > Cordless Tools*.
6. Open the *WLAN AP Configuration*.
7. Carry out the desired settings for the configuration of the access point.
8. Press <Apply> to save the changes.

This tab is only displayed for the series mPro200GC(-AP) controller.

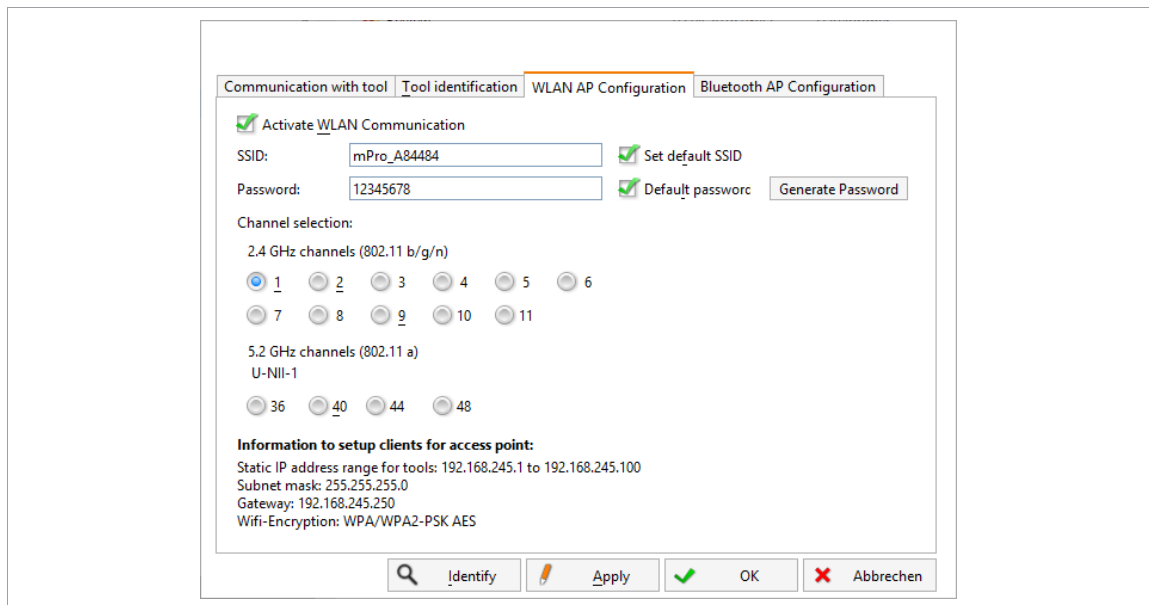

Fig. 4-1: WLAN AP Configuration tab

Parameter	Description
Activate WLAN Communication	If the checkbox is activated, WLAN is enabled on the controller. ➤ The bluetooth function is deactivated.
SSID	Enter the SSID for the WLAN name (access point) to which a connection is to be established.
Set default SSID	If the <i>Set default SSID</i> checkbox is activated, then a default value for the SSID is assigned.
Password	Enter the password for the access point. The default password is visible. As soon as a new password is assigned, asterisks * are displayed instead of numbers.
<Generate Password>	Press <Generate Password> to generate any eight-digit password.
Default Password	If the <i>Default Password</i> checkbox is activated, then the default password is displayed.
Channel bands	Select the frequency band. Only one channel can be selected. The following may be selected: <ul style="list-style-type: none"> <li>• 2.4 GHz</li> <li>• 5.2 GHz</li> </ul>
2.4 GHz channels (802.11 b/g/n)	Select channel. Only one channel can be selected. Only active if the 2.4 GHz frequency band has been selected.
5.2 GHz channels (802.11 a)	Select channel. Only one channel can be selected. Only active if the 5.2 GHz frequency band has been selected.
Information to setup clients for access point	Access point information: <ul style="list-style-type: none"> <li>• Range of IP addresses for tools</li> <li>• Subnet mask</li> <li>• Gateway</li> <li>• WLAN encryption</li> </ul>
<Identify>	Update the view of the WLAN settings.
<Apply>	Save the settings.
<OK>	Exit software, the settings are saved.
<Cancel>	Exit software, the settings are not saved.

For all other settings, default values are assigned, which cannot be changed.



If the PC cannot establish a connection to the controller, then the settings can be made via a monitor connected to the controller.

#### Make settings via monitor

1. Connect a monitor via a VGA connection, as well as a keyboard and a mouse, to the controller.
  - The software user interface for the controller appears on the screen.
2. *Navigator> Utility > System Settings > Cordless Tools* wählen.
3. Open the *WLAN AP Configuration*.
4. Carry out the desired settings for the configuration of the access point.
5. Press <Apply> to save the changes.

#### 4.1.2 mPro400GCD

To configure an access point to work with a mPro400GCD, see document *P2260JH*.



## 4.2 Configuring RF settings

The tool RF settings can be configured with a laptop/PC. Perform the following steps only when WLAN communication is to be established.

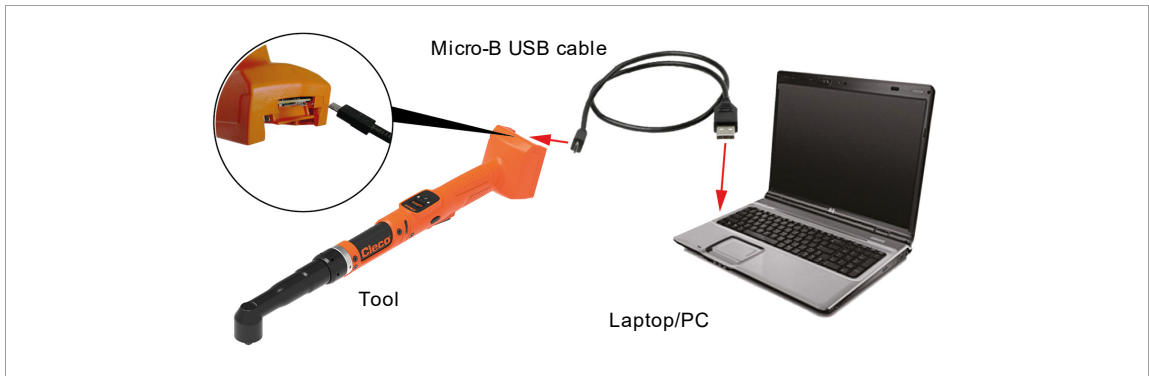

Fig. 4-2: LiveWire Utilities

### Configuring tool RF settings

1. Connect the tool to the PC via a Micro B USB cable.
  - The tool switches on automatically.
  - The following screen is displayed on the tool:



Fig. 4-3: Display when the tool is connectd to a PC

2. Determine the serial interface (COM port) for the driver in the device manager for the PC.

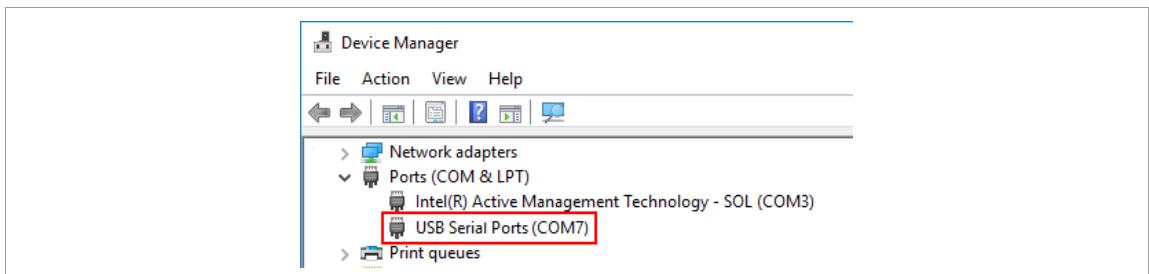

Fig. 4-4: Device manager

3. Starting the *Cordless RF Configuration* under *Apex Tool Group*.

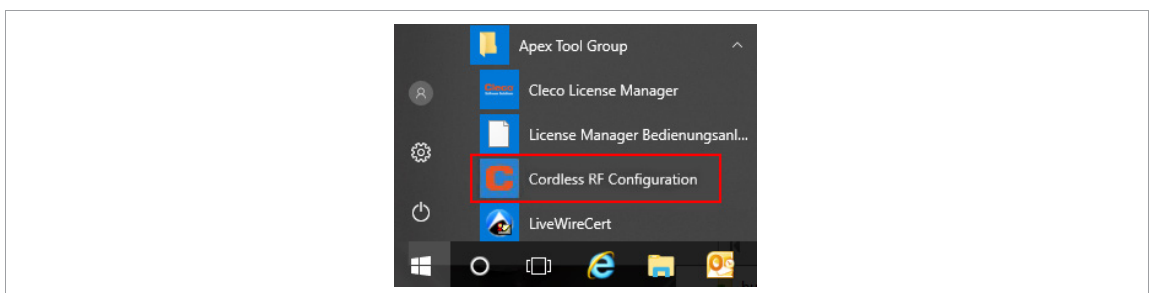

Fig. 4-5: Starting the *Cordless RF Configuration* program

4. For an *IRDA Connection*, select the serial interface (COM port) for the driver.
5. Select <Identify> to read out the specific data of the WLAN module.

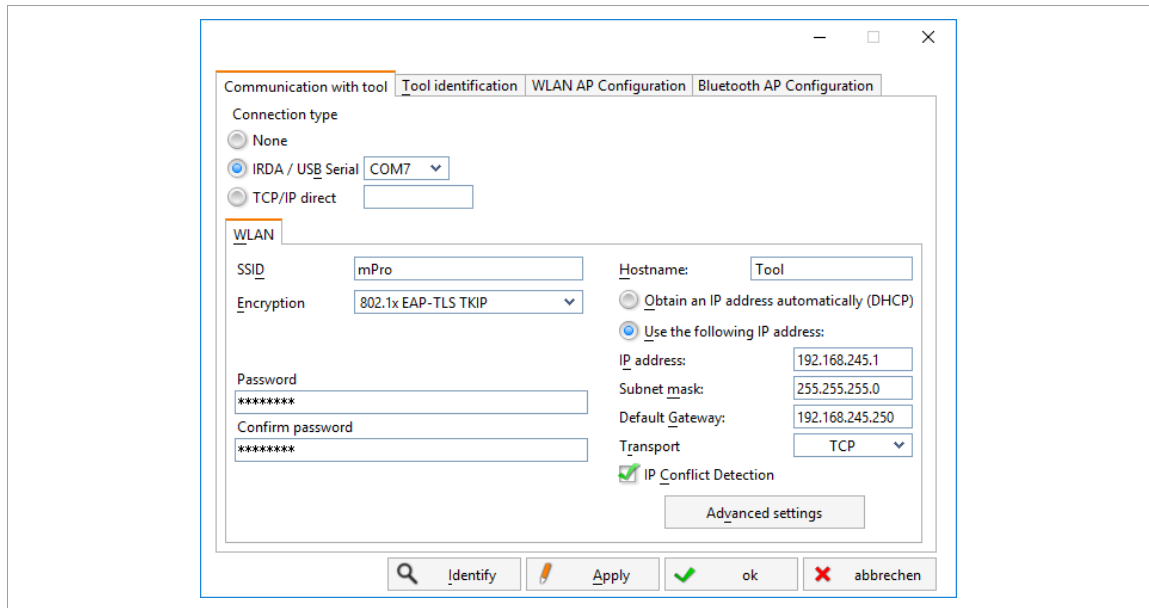

Fig. 4-6: Communication with tool tab

Parameter	Description
SSID	Enter SSID. SSID must be identical to the access point.
Encryption	Select security. <i>Encryption</i> must be identical with access point.
Network key	Enter the network key. The network key must be identical to the access point.
Confirm network key	Confirm network key.
Hostname	Optionally, a hostname can be entered.
Obtain an IP address automatically (DHCP)	Do not select this option. IP address is assigned automatically.
Use the following IP address	Enter IP address manually with the following parameters.
IP address	Enter the IP address. In the last block, numbers between 1 and 49 can be assigned as a static address.
Subnet mask	Enter the subnet mask.
Default Gateway	IP address that is assigned by the access point.
Transport	Select TCP.
IP conflict Detection	This setting is only available for LiveWire tools with the C2 or C3 measuring card. If the check box is selected, duplicate IP addresses are detected.

6. To set the radio channel, select <Advanced settings>.  
➤ The *WLAN Advanced settings* window opens.

Parameter	Description
Wireless mode	Select WLAN mode: <ul style="list-style-type: none"> <li>Select 802.11b/g/n if a frequency band of 2.4 GHz is used.</li> <li>Select 802.11a if a frequency band of 5 GHz is used.</li> </ul>
5.2 GHz radio band (802.11a)	Select a frequency band. This setting is only possible if the 5 GHz frequency band has been selected.

Parameter	Description
Wireless channel	There are two setting options: <ul style="list-style-type: none"> <li>• <i>Auto</i> The corresponding channel is automatically searched for.</li> <li>• The channels are unlocked and can be selected manually.</li> </ul>
<Scan channels>	Scan radio channel. The button is not active if a channel is selected at <i>Wireless channel</i> .
Transmit power	Set transmission power.
Roaming Aggressiveness	Setting option, from which signal strength the tool connects with another access point.
<OK>	Exit the input window, the settings are saved.
<Cancel>	Exit input window, the settings are not saved.

7. Confirm settings with <OK>.
8. Press <Apply>.
  - Settings are written onto the tool.
9. Confirm the following message with <Yes>:  
**Toolserial: xxxxxxxx**  
**Builddate: xx.xx.xx**  
**Configure Tool?**
10. Confirm the following message with <OK>:  
**Configuration done!**
11. Installing the tool on the controller.

### 4.3 Installing the Tool

Up to ten tools can be connected to one controller via WLAN.  
 Up to seven tools can be connected to one controller via Bluetooth.

1. Select *Navigator> Tool Setup* on the user interface of the controller.
2. Press <Install> to add a tool to the tool list.
3. Carry out the following settings:

Parameter	Description
Group Name	▶ Select Tool Group.
Name	▶ Select Tool Group.
Type	▶ Select <i>CellClutch</i> .
IP address / hostname	▶ Enter the IP address that has been assigned to the tool using the <i>LiveWire Utilities</i> software.

4. Press <OK> and save the settings.
  - The Tool List is displayed.
  - Status of tool is now *Needs User Acceptance*.
5. Select <Tool Settings>.
6. Check the *Model Number* and *Serial Number* and confirm that the tool displayed corresponds to the tool connected.
7. Save the settings with <Accept>.
  - The Tool List is displayed. Status of tool is now *Online*.
8. To save the settings, select <Navigator>.
9. For additional programming for tightening (e.g., PG), see document *P2280PM*.

## 5 Menus And Functions

### 5.1 General Functions



All paths are specified starting from the main menu.



- ▶ To go from the runscreen to the main menu, press the  key.

#### 5.1.1 Switching On The Tool

- ▶ To switch on the tool, press the start trigger.





#### 5.1.2 Switching Off Tool

There are several ways to switch off the tool.

##### Option 1:

- ▶ Remove the battery.
  - Tool switches off after 20 seconds.

##### Option 2:

1. Select  > .
2. Press the  button.
  - The  symbol is displayed on the LCD.
  - After five seconds, the tool switches off.

##### Option 3:

The tool will switch off if it is not used for a certain time, see *chapter 5.8.4 Setting the shut-off properties, page 36*.



#### 5.1.3 Selecting a button

When talking about pressing a button in this manual, this means the following:



1. Use the arrow buttons to navigate to the desired button (outlined in blue).
2. Press the  button.

#### 5.1.4 Changing parameters

Enter the parameter by changing each character of the value individually. Each character can have a maximum value of nine.

1. Press the  button.
  - The value is highlighted in red and an arrow is displayed below the first digit. This digit can be changed.
2. Change the selected digit using the arrow buttons.
3. Confirm with the  button.
  - The next digit can be changed.
4. Repeat the procedure with each digit of the value.
5. After the last digit confirm the input with the  button to save the input.

### 5.1.5 Change between FastApps and mPro mode

1. Select  > .
2. Press the  button to switch between modes.

 FastApps mode is activated.

 mPro mode is activated. A connection to the controller is necessary, see document P2545KA.

### 5.2 CID (CellTek ID Card)

To permit simple replacement of tools in production, a replaceable CID memory card is installed. When the tool is switched on, the network settings are read from the CID and used to establish the WLAN connection.

When the tools are changed, the CID must be installed in the new tool being used. Please refer to P2543BA.

The following data are stored on the CID:

- MAC address
- Network name (SSID)
- Encryption
- Network key
- Use of the DHCP server
- IP address
- Subnet mask
- Gateway
- Country-specific settings
- Roaming settings
- Channel selection
- Network certificates
- API license
- FastApps configuration and archive
- Tool settings

To permit simple replacement of tools in production, a replaceable CID memory card is installed. When the tool is switched on, the network settings are read from the CID and used to establish the WLAN connection. When the tools are changed, the CID has to be installed in the new tool being used. Please refer to P2543BA.

### 5.3 Display

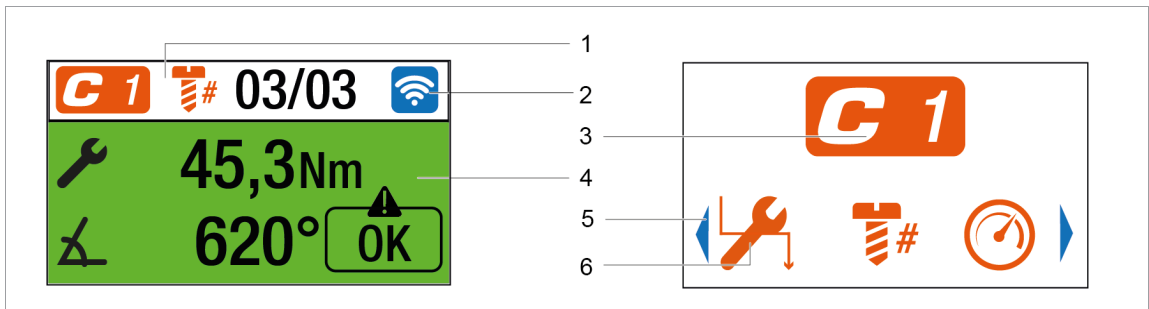







Fig. 5-1: Setup of the menus using the run screen and a submenu as an example

Item	Description
1	Application/Linking group/FastApp selection
2	Symbol of the current communication connection
3	Symbol of the current menu
4	Rundown result
5	Arrow left and right indicates that there are other menu items available that are not yet displayed on the LCD. To reach them, press  or  .
6	Submenus Press  button to display the parameters

**General presentation of the buttons**

Button	Description
	Button is in color: Function selectable.
	Button highlighted in gray: Function disabled.

5.4 Menu structure overview

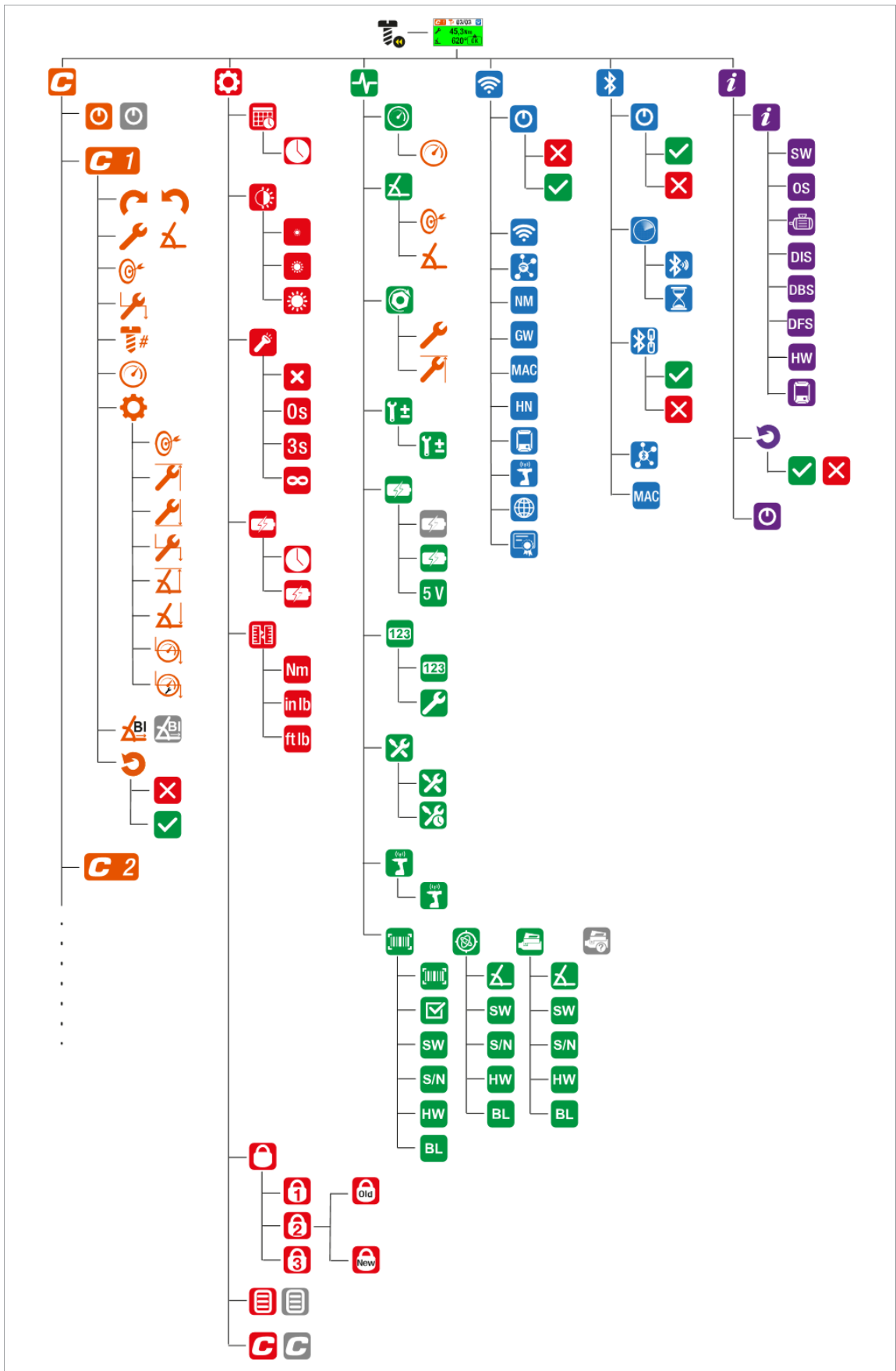

## 5.5 Run screen

The run screen displays the rundown data for the tightening sequence. The structure of the run screen is equal in mPro and FastApps mode.

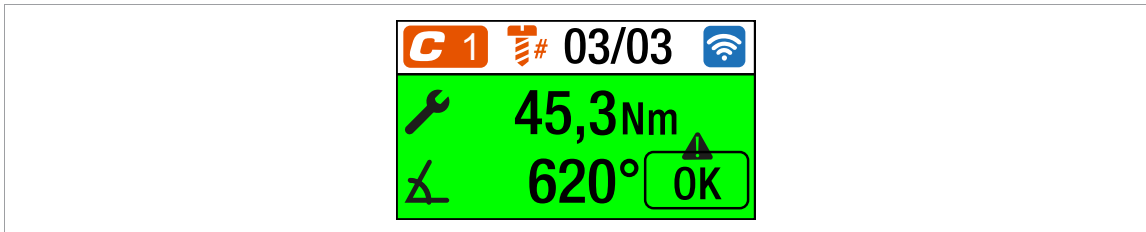











Fig. 5-2: Run screen with a rundown result of the FastApp 3

Symbol	Description
	Display of the currently selected FastApp.  Up to ten FastApps can be programmed. The number on the button indicates which FastApp is selected.
	Display of the currently selected Application or Linking group (mPro). Up to 99 Applications/Linking groups can be programmed. The number on the icon indicates which Linking group is selected.
	Number of tightening positions for a application/batche. <ul style="list-style-type: none"> <li>If there is only one FastApp, then each result is evaluated.</li> <li>If there is more than one FastApp, the overall result of all the tightening positions is considered.</li> </ul> Example: 2/3 <ul style="list-style-type: none"> <li>Current tightening position: 2</li> <li>Total number of tightening positions: 3</li> </ul>
	Number of repeats when a rework is performed due to NOK rundown. This function is only available in mPro mode.
	The symbol that appears shows the available WLAN or Bluetooth connection. If the symbols are grayed out, no WLAN/Bluetooth connection could be established yet.
	
	Display of the torque for the current tightening. If an arrow pointing up appears next to the symbol, the result is too high. If an arrow pointing down appears next to the symbol, the result is too low.
	Display of the angle for the current tightening. If an arrow pointing up appears next to the symbol, the result is too high. If an arrow pointing down appears next to the symbol, the result is too low.
	Display of the rundown status, see <i>chapter 7.2 Error messages, page 58</i> .



### 5.5.1 Selecting the FastApps

- To change between the FastApps, press or .
  - Only Linking groups that have already been parameterized can be selected.
- Press the button to select the new FastApp.

If the FastApp is blocked (under: > ) , then the selection options are not available. In this case, a PIN must be entered to switch to another Linking group. A requirement is that a PIN has been defined in the PIN menu ( > ).

### 5.5.2 Selecting the Application/Linking group

To be able to switch between the Applications/Linking groups in mPro mode, the *External Application / LG Selection* must be activated on the controller.

- Select *Navigator > Advanced > Tool Group > I/O* on the controller.
- Activate the checkbox *External Application / LG Selection*.
- In *Mode* select the *Tool Menu (Cordless Tool)*.
- To save the settings, press <Navigator>.
- To change between the Applications/Linking groups on the tool, press or .
  - Only Applications/Linking groups that have already been parameterized can be selected.
  - A new display appears with the following selection options:



Button	Description
	▶ Press the  button to select a new Application/Linking group.
	▶  must be pressed to cancel the process and return to the run screen.

The Application/Linking group can also be changed when the tool or control is offline. However, the run-down cannot be done until the connection between tool and control has been re-established.





### 5.5.3 Status Indication

Status light	Operating status	Result after fastening cycle
	Active	OK 
	Active	NOK 
	Back-off <sup>1</sup>	–
If linking is selected on the controller:		
	Active/Setting: Linking	Linking OK 

<sup>1</sup> only in mode when the *Blink Lights When Tool in Reverse* check box is activated at the controller under *Navigator > Advanced > Tool Group > I/O*.

Status light	Operating status	Result after fastening cycle
	Active/Setting: Linking	Linking NOK 

### Legend

Symbol	Explanation
	Green LED lights up
	Red LED lights up
	Yellow LED lights up
	Break

### 5.5.4 Counterclockwise rotation

In the *Counterclockwise Rotation* menu, the tool rotates in the opposite direction of rotation as programmed for the FastApp in the controller or in the FastApps menu. During tightening, the display flashes yellow-gray.

The speed for the counterclockwise rotation starts at 20 rpm and increases to 300 rpm or the maximum tool speed, if this is lower than 300 rpm.



Fig. 5-3: Display during counterclockwise rotation

1. To activate the counterclockwise rotation press one of the reverse switches.
2. Press the start button to loosen a rundown with counterclockwise rotation.
3. To return to the run screen, press one of the reverse switches again.

### 5.6 Main menu







- ▶ To go from the run screen to the main menu, press the  button.



Fig. 5-4: Main menu

Button	Description
	FastApps menu

Button	Description
	FastApps menu is deactivated If the maximum capacity of the tool is too high, the FastApps configuration is not possible. High torque tools can only be configured in mPro mode.
	Settings
	Diagnostics
	WLAN communication
	Bluetooth communication
	Utility

## 5.7 FastApps menu

The FastApps menu is used to parameterize FastApps. In the mPro mode, the FastApps menu has no function.

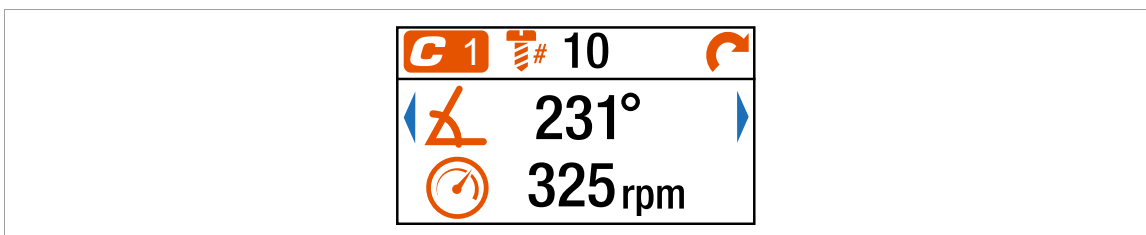











Fig. 5-5: Menu – FastApps menu

Button	Description
	FastApps mode is activated. ➤ mPro mode is disabled.
	FastApps mode is disabled. ➤ mPro mode is active.  Only the parameters for the selected mode apply. If the mode is changed, the current settings will not be carried over to the new mode.

Button	Description
	Display of the currently selected FastApp.  Up to ten FastApps can be programmed. The number on the button indicates which FastApp is selected.
	FastApp with torque shut-off.  The number to the right of the symbol indicates the shut-off torque. The unit corresponds to the selection, see <i>chapter 5.8.5 Selecting the torque units, page 36</i> .
	FastApp with angle shutoff.  The number to the right of the symbol indicates the shut-off angle.
	Batch display
	Display of the selected direction of rotation. Depending on the selected direction of rotation, one of the two symbols is displayed.
	
	Start speed display.

### 5.7.1 Configuring FastApps

Up to ten FastApps can be programmed. The maximum tightening time is ten seconds.

 > 

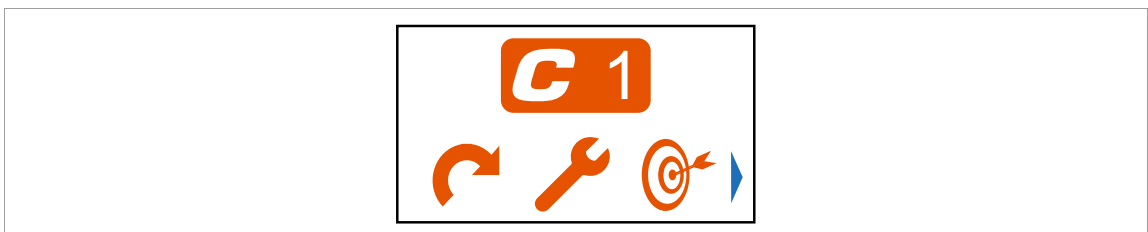















Fig. 5-6: Submenu – Configuring FastApps

Button	Description
	Display of the selected direction of rotation. Depending on the selected direction of rotation, one of the two symbols is displayed.

Button	Description																								
																									
	<p>Display of the tightening strategy. Depending on the selected shut-off, one of the symbols will be displayed. One torque and one angle shut-off is possible.</p> <ul style="list-style-type: none"> <li>• Display of the torque shutoff</li> </ul>																								
	<ul style="list-style-type: none"> <li>• Display of the angle shutoff.</li> </ul>																								
	<ul style="list-style-type: none"> <li>▶ For a torque shutoff, enter the shut-off torque.</li> <li>▶ For an angle shutoff, enter the shut-off angle.</li> </ul> <p>Once the value has been reached, the tightening process is completed. This setting option is the same as in the menu <i>Advanced Settings</i>.</p> <p><b>Note</b></p> <p>If the shut-off value is entered here in the <i>Configuring FastApps</i> menu, then the following values are calculated automatically:</p> <table border="1"> <thead> <tr> <th>Parameter</th> <th>Shut-off Torque</th> <th>Shut-off Angle</th> </tr> </thead> <tbody> <tr> <td>Minimum Torque</td> <td>-15% of the Shut-off Torque</td> <td>Threshold Torque</td> </tr> <tr> <td>Maximum Torque</td> <td>+15% of the Shut-off Torque</td> <td>Tool capacity</td> </tr> <tr> <td>Minimum Angle</td> <td>0</td> <td>-10 deg of the Shut-off Angle</td> </tr> <tr> <td>Maximum Angel</td> <td>9999</td> <td>+10 deg of the Shut-off Angle</td> </tr> <tr> <td>Threshold Torque</td> <td>50% of the Shut-off Torque</td> <td>Manual input</td> </tr> <tr> <td>Final Speed</td> <td>50</td> <td>50</td> </tr> <tr> <td>Speed Threshold</td> <td>1/4 x of the Shut-off Torque</td> <td>Threshold Torque</td> </tr> </tbody> </table> <p>These values can be changed manually in the  menu, see <i>chapter 5.7.4 Advanced Settings, page 31</i>.</p>	Parameter	Shut-off Torque	Shut-off Angle	Minimum Torque	-15% of the Shut-off Torque	Threshold Torque	Maximum Torque	+15% of the Shut-off Torque	Tool capacity	Minimum Angle	0	-10 deg of the Shut-off Angle	Maximum Angel	9999	+10 deg of the Shut-off Angle	Threshold Torque	50% of the Shut-off Torque	Manual input	Final Speed	50	50	Speed Threshold	1/4 x of the Shut-off Torque	Threshold Torque
Parameter	Shut-off Torque	Shut-off Angle																							
Minimum Torque	-15% of the Shut-off Torque	Threshold Torque																							
Maximum Torque	+15% of the Shut-off Torque	Tool capacity																							
Minimum Angle	0	-10 deg of the Shut-off Angle																							
Maximum Angel	9999	+10 deg of the Shut-off Angle																							
Threshold Torque	50% of the Shut-off Torque	Manual input																							
Final Speed	50	50																							
Speed Threshold	1/4 x of the Shut-off Torque	Threshold Torque																							
	<p>Entering the Threshold Torque.</p> <p>This button is only displayed during angle shutoff. This setting option is the same as in the menu <i>Advanced Settings</i>.</p>																								
	<p>Batch display</p> <p>Enter the number of tightening positions for a FastApp.</p>																								
	<p>Start Speed display.</p> <ul style="list-style-type: none"> <li>▶ Enter the Start Speed.</li> </ul>																								

Button	Description
	Advanced settings.
	Block Angle Detection activated.  If block angle detection is enabled, a block angle of 180° is added to torque/angle shutoff. This block angle is used at the start of rundown, to detect if screw is already tighten or thread/screw damaged or crooked screwed-in. The angle counting starts after the block angle.  So if within that first 180° the torque exceeds the shutoff-torque (torque shutoff) or maximum torque (angle shutoff), the rundown is aborted and the "BLOC" error is show.
	Block Angle Detection disabled.
	Reset FastApps.

### 5.7.2 Selecting the direction of rotation

 >  > 



Fig. 5-7: Submenu – Selecting the direction of rotation

Button	Description
	Direction of rotation, right-hand thread.
	Direction of rotation, left-hand thread.

### 5.7.3 Selecting the tightening strategy

**G** > **G1** > 

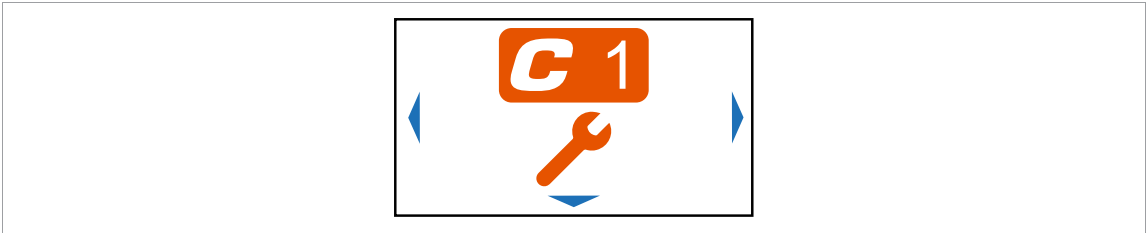



Fig. 5-8: Submenu – Selecting the tightening strategy





Button	Description
	Torque shutoff Sequence 31: Shut-off torque controlled tightening sequence with torque and rotation angle check, see chapter 6 Tightening sequence, page 55.
	Angle shutoff Sequence 51: Shut-off angle controlled tightening sequence with rotation angle and torque check, see chapter 6 Tightening sequence, page 55.





### 5.7.4 Advanced Settings

**G** > **G1** > 



Fig. 5-9: Submenu – Advanced Settings

Button	Description
	<ul style="list-style-type: none"> <li>▶ For a torque shutoff, enter the Shut-off Torque.</li> <li>▶ For an angle shutoff, enter the Shut-off Angle.</li> </ul> <p>Once the value has been reached, the tightening process is ended. This setting option is the same as in the menu see chapter 5.7.1 Configuring FastApps, page 28.</p>
	<p><b>Note</b></p> <p>If the shut-off value is entered here in the <i>Advanced Settings</i> menu, the minimum and maximum torque, the minimum and maximum angle, as well as the threshold torque, are not calculated automatically.</p>
	<ul style="list-style-type: none"> <li>▶ Display of the Maximum Torque.</li> </ul>
	<ul style="list-style-type: none"> <li>▶ Display of the Minimum Torque.</li> </ul> <p>The Minimum Torque can not be greater than the Shut-off Torque and must be at least as great as the Threshold Torque.</p>





Button	Description
	▶ Entering the Threshold Torque.
	▶ Enter the Maximum Angle.
	▶ Enter the Minimum Angle.
	▶ Enter the Final Speed.
	▶ Enter Speed Threshold. As soon as the Speed Threshold is reached, the speed immediately changes from the start speed to the Final Speed up to the Maximum Torque.

### 5.7.5 Resetting FastApp

 >  > 



Fig. 5-10: Submenu – Resetting FastApps

Button	Description
	▶ Select this button to cancel the process. Leave the menu press and hold the  button.
	▶ Select this button and confirm with the  button to reset the settings of the FastApp. > All settings for the selected FastApp are deleted. > The FastApp is no longer parameterized and no parameter settings are displayed in the <i>Configuring FastApps</i> menu



5.8 Settings

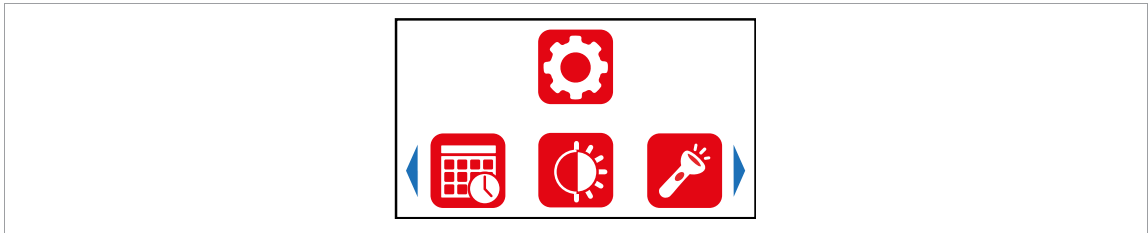



Fig. 5-11: Menu – Settings

Button	Description
	Display and set time and date.
	Adjust screen brightness.
	Adjust tool light.
	Set shut-off properties.
	Select torque units.
	PIN menu
	Lock menu
	Allow Linking group selection.







### 5.8.1 Setting the date and time



Fig. 5-12: Submenu – Setting the date and time

Button	Description
	Time display Presentation: Hour : Minute
	Display of the date Presentation: Day.Month.Year

#### Change date or time

- To activate the input fields, press the  button. Each digit can be changed individually.
  - The value is highlighted in red and an arrow is displayed below the first digit. This digit can be changed.
- Use the  and  buttons to increase/decrease the numbers.
- Confirm with the  button and activate the next digit.
- Repeat the procedure with each digit to change the time and date one by one.
- After the last digit confirm the input with the  button to save the input.
- To leave the menu, press and hold the  button.
  - The change is saved.

### 5.8.2 Adjusting the screen brightness

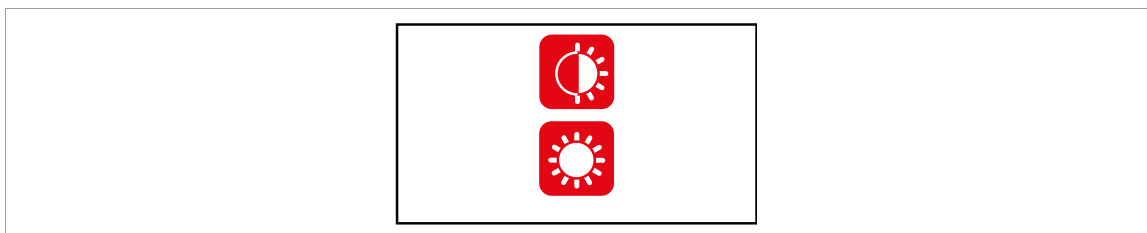





Fig. 5-13: Submenu – Screen brightness

- Press the  button to switch between the following options. The visible option is active.

Button	Description
	Brightness Level 1: The LCD is dark and dimly lit.

Button	Description
	Brightness Level 2: The LCD has medium illumination. This is the default setting that is used when none of the buttons are selected (outlined in green).
	Brightness Level 3: The LCD is brightly lit.





### 5.8.3 Adjusting the tool light

This menu is only available in the FastApps mode. The tool light illuminates the tightening position.



Fig. 5-14: Submenu - Adjusting the tool light

► Press the  button to switch between the following options. The visible option is active.

Button	Description
	Tool light disabled. Tool light never goes on.
	Tool light will only go on when the Start switch is pressed halfway. During tightening, it is switched off.
	Tool light is on as long as the Start switch is pressed halfway. If the Start switch is pressed all the way, the tool light will go on for three seconds before it switches off.
	Tool light is on as long as the Start switch is pressed. Tool light is on during the tightening process until the Start switch is released.

### 5.8.4 Setting the shut-off properties

This menu is only available in the FastApps mode. In the mPro mode, the values can only be changed via the controller.

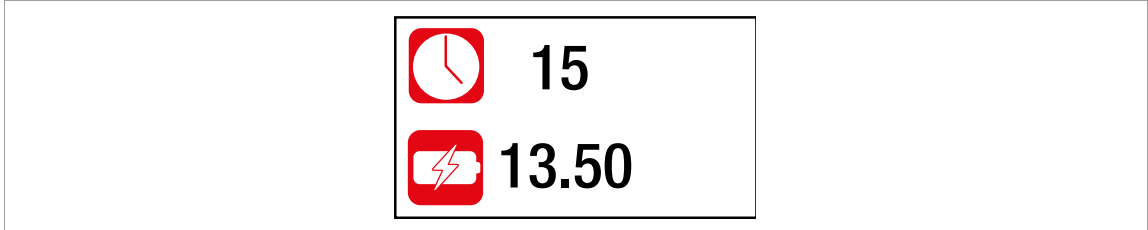



Fig. 5-15: Submenu – Setting the shut-off properties

Button	Description
	Shutoff after idle mode. Enter the time in minutes after which the tool switches off if no button or key has been pressed.
	The undervoltage limit indicates when a battery change is necessary. If the battery voltage falls below the defined value, a gray battery symbol flashes on the display and the same symbol appears in the header.

### 5.8.5 Selecting the torque units

The torque values on the run screen are displayed in the selected units. The selection is also used for the data export.

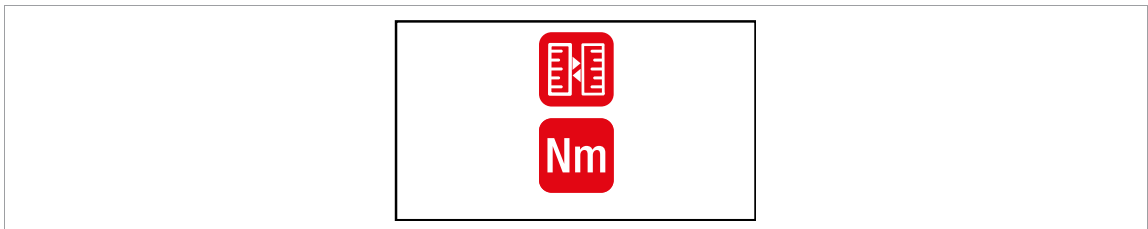





Fig. 5-16: Submenu – Selecting units

- ▶ Press the  button to switch between the following options. The visible option is active.

Button	Description
	Units Newton-meters
	Units inch-pounds
	Units foot-pounds

### 5.8.6 Setting the PIN

Up to three PINs for three access levels can be defined. With the access levels, different menus can be available. If a PIN is defined, then the menu can be opened. However, changes can only be made after entering the required PIN.

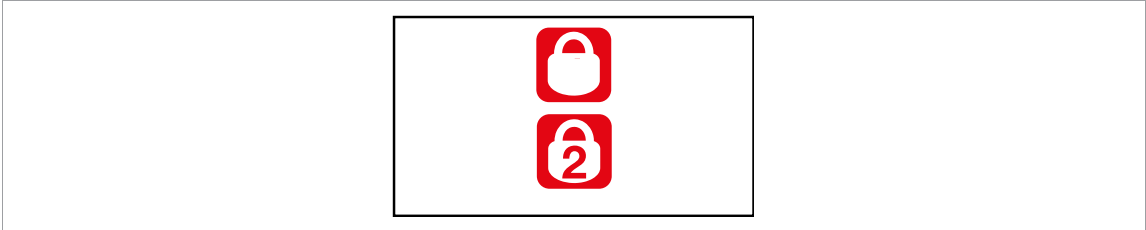



Fig. 5-17: Submenu – PIN menu

Button	Description
	Access Level 1 Valid for the menu:  
	Access Level 2 Valid for the menu:     
	Access Level 3 Valid for the menu:      

If only one PIN is defined, then it applies to all the access levels. PINs for higher access levels also apply to the lower access levels.

	PIN 1	PIN 2	PIN 3
<b>Access Level 1</b>	x	x	x
<b>Access Level 2</b>		x	x
<b>Access Level 3</b>			x

Example:

The following PINs are defined: PIN 1: 1111                      PIN 2: 2222                      PIN 3: 3333





If asked for PIN 2, both PIN 2 (2222) and PIN 3 (3333) can be entered to access a menu. However, PIN 1 (1111) is invalid.

#### Entering a PIN



Fig. 5-18: Submenu – Entering a PIN

### Enter a PIN (a PIN consists of four numbers)

1. Enter four numbers. The number on the lock indicates which PIN must be entered.
  - Use the  and  buttons to increase/decrease the numbers between 0 and 9.
  - Use the  button to switch between four input fields.
2. Confirm the PIN with the  button.
  - If the menu is opened, the pin is correct.
  - If the arrow jumps back to the first number, the pin is wrong.

After unlocking, the tool will lock again if no action is taken for two minutes or if a switch is made to the run screen.

### Changing a PIN

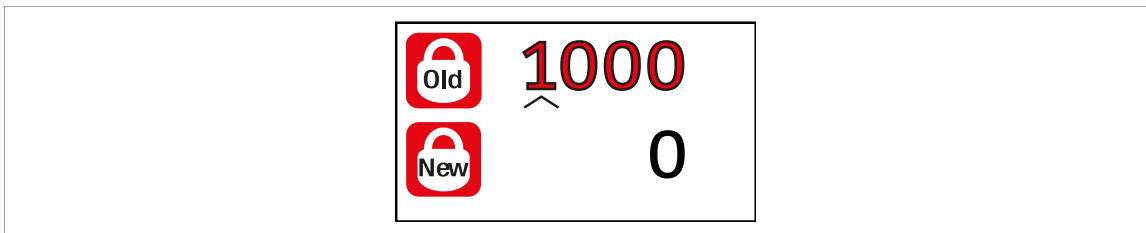













Fig. 5-19: Submenu – Changing a PIN

Button	Description
	Entering an old PIN.
	Entering a new PIN.

### Change a PIN

1. Navigate to *Changing a PIN*  >  and select one of the three access levels   .
2. Press the  button to activate the input box. The numbers are entered individually.
3. For , enter the old PIN. If no PIN was previously defined, enter 0000.
4. For , enter the new PIN. The PIN must not be 0000.
5. save the PIN, press .
  - The new PIN is activated and the menu is exited.

### Deactivating a PIN

- ▶ For , enter 0000 to deactivate a PIN.

### 5.8.7 Locking a menu

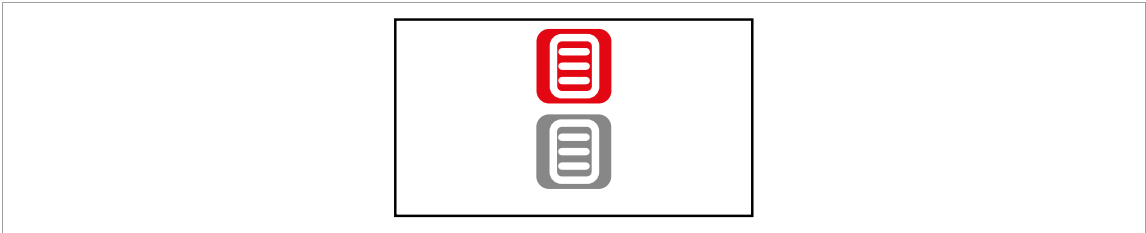

Fig. 5-20: Submenu – Locking a menu

Button	Description
	<p>Lock activated.</p> <p>To open the main menu from the run screen, a PIN must be entered. Unlocking is possible with each access level. The requirement is that a PIN has already been defined.</p>
	<p>PIN lock disabled.</p> <p>All menus can be opened without entering a PIN.</p>

### 5.8.8 Allowing a Linking group/FastApp selection

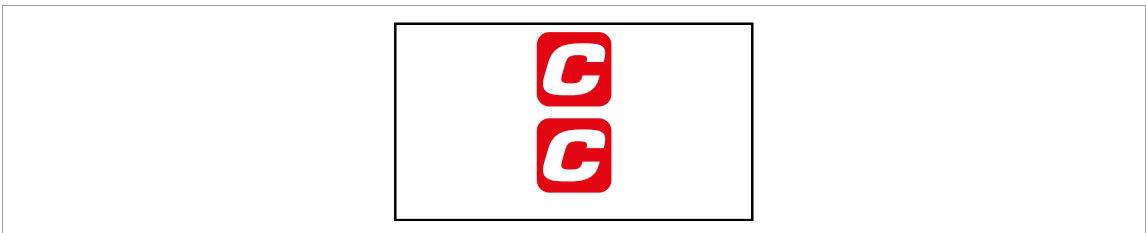

Fig. 5-21: Submenu – Allowing a Linking group/FastApp selection

Button	Description
	<p>Lock activated.</p> <p>Requirement: A PIN must be activated.</p> <p>To switch to another Linking group/FastApp from the run screen, a PIN must be entered. The functionality of the Start switch is not restricted.</p>
	<p>Lock disabled.</p> <p>Switching between all the parameterized Linking groups/FastApps can be carried out in the run screen. There is no need to enter a PIN.</p>

## 5.9 Diagnostics



### Caution

#### Winding hazard

The rotation of the output can cause severe finger injuries.

- ▶ Never reach into the rotating parts of the tool.
- ▶ Make sure that the rotation of the tool does not pose any danger.
- ▶ Do not perform diagnostic tests on the workpiece. Perform the test with a freely rotating tool.

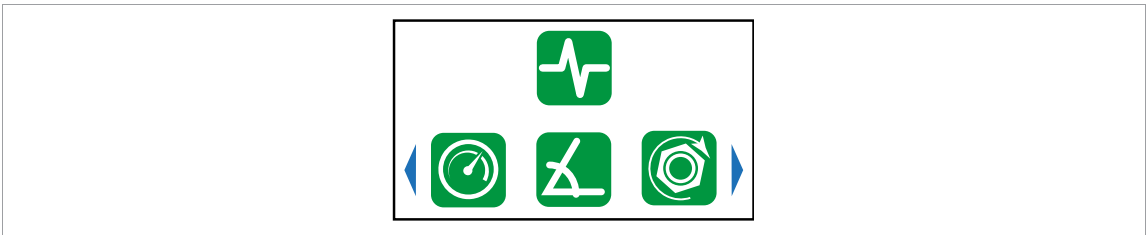













Fig. 5-22: Menu – Diagnostics

Button	Description
	Speed test
	Angle test
	Torque test
	Calibration value
	Voltage
	Counters status
	Maintenance counter
	Tool constant
	<p>If an accessory is used, one of the buttons is displayed depending on the type:</p> <ul style="list-style-type: none"> <li>• 2D Reader</li> </ul>



Button	Description
	<ul style="list-style-type: none"> <li>• Gyroscope</li> </ul>
	<ul style="list-style-type: none"> <li>• Combi Accessory</li> </ul>
	<ul style="list-style-type: none"> <li>• Accessory is not detected</li> <li>▶ Perform software update with a newer software version. The latest software version can be found at: <a href="https://software.apextoolgroup.com/current-software-packages/celltek/">https://software.apextoolgroup.com/current-software-packages/celltek/</a></li> </ul>

### 5.9.1 Speed test

This test function enables an evaluation of the speed.

The speed measurement is based on the angle information from the motor. If the start button is released, the tool stops. As a safety function, the torque is monitored by the tool transducer. If it exceeds 15% of its calibrated value, the speed measurement is terminated.

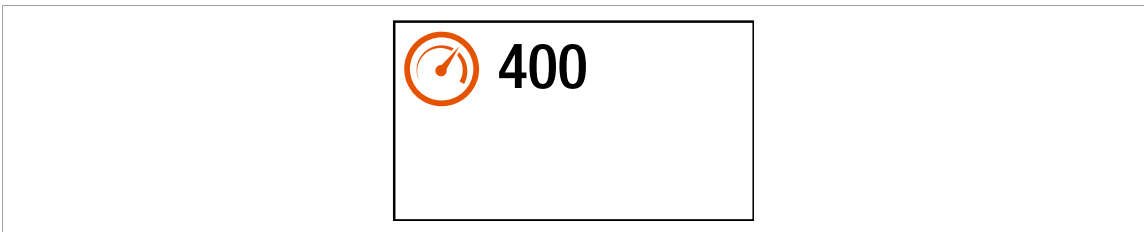



Fig. 5-23: Submenu – Speed test

Symbol	Description
	<ul style="list-style-type: none"> <li>▶ Keep the Start switch pressed.</li> <li>➤ The tool runs at maximum speed.</li> <li>➤ The current speed is displayed.</li> </ul>

### 5.9.2 Angle test

This test function allows an evaluation of the angle measurement.

By using the Start button, the tool starts with 25% of the maximum speed. The speed is limited to a maximum of 60 rpm. After one revolution at the output (target angle 360°), the tool is stopped. During a fixed dwell time of 200 ms, any possible angular pulses are still detected. The total result is shown as the Actual Angle.

If the test run is not aborted by a monitoring criterion and the total result is greater than or equal to 360°, then it is evaluated as OK and displayed. Monitoring criteria are the torque and a monitoring time.

If the torque exceeds 15% of the calibration value (even during the dwell time), or if the monitoring time lasts four seconds, then the test run is aborted with an Tq> or TMAX evaluation. However, you must check for yourself whether the output has rotated by the displayed value (e.g., make a mark).



Make sure that the output shaft has rotated by the indicated number of revolutions (e.g., by marking its position). If the rotation made by the output shaft does not match the displayed value, either an incorrect angle factor has been set or the angle sensor is defective.

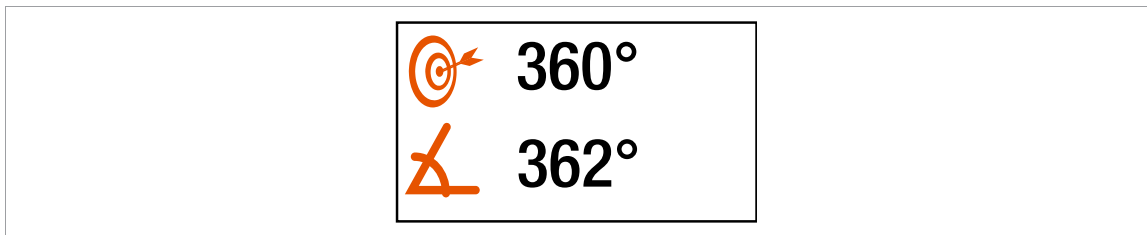



Fig. 5-24: Submenu – Angle test

- To start the tests, keep the start trigger pressed.

Symbol	Description
	Display of the shut-off angle of 360°.
	Display of the angle. The displayed angle should be close to 360°.

### 5.9.3 Torque test

With the torque test, the functionality of the measuring sensor can be checked, and the torque measurement can be evaluated.

At the beginning of the test, the torque is 0 Nm. Throughout the entire test, the torque is measured and displayed.

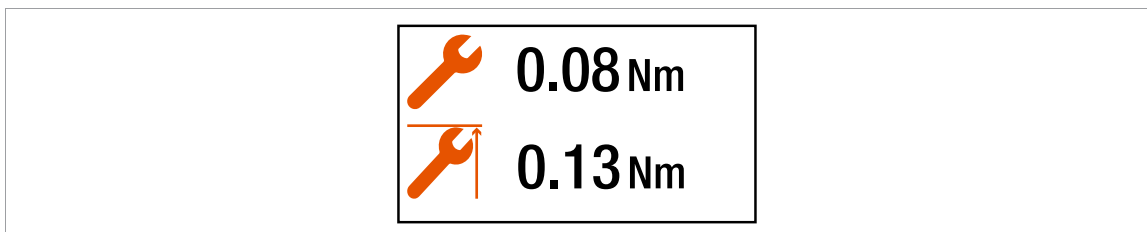



Fig. 5-25: Submenu – Torque test

- To start the tests, keep the start trigger pressed.

Symbol	Description
	Display of the current torque.
	Display of the maximum torque.

### 5.9.4 Calibration value

This test function allows an evaluation of the calibration voltage.

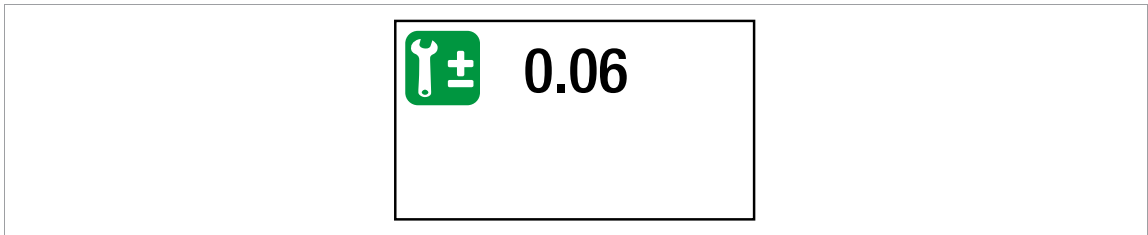



Fig. 5-26: Submenu – Calibration value

Button	Description
	<p>Display of the neutral position value for the measuring sensor.</p> <p>The displayed value should be at 0 V. The tolerance limits are <math>\pm 0.2</math> V.</p>

### 5.9.5 Voltage

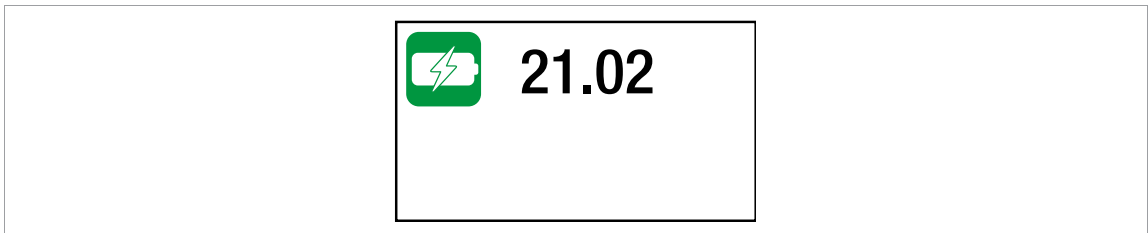





Fig. 5-27: Submenu – Voltage

Button	Description
	<p>Display of the undervoltage limit.</p> <p>This limit can be set in the menu <i>Setting the shut-off properties</i>.</p>
	<p>Display of the current battery voltage.</p> <p>For high operational capability, this voltage is continuously monitored during the tightening process. If the voltage drops below the undervoltage, a warning is issued on the tool, see <i>chapter 5.8.4 Setting the shut-off properties, page 36</i>.</p>
	<p>Display of the logic voltage of 5 V.</p> <p>A voltage for components that are not needed for the core functions of the tool. The tolerance limits are <math>\pm 5\%</math>.</p>

### 5.9.6 Counters status



Fig. 5-28: Submenu – Number of tightenings

Button	Description
	Display of the number of all previous tightenings.

### 5.9.7 Maintenance Counter

Tool maintenance information helps to keep the tool in regular circulation for maintenance and service. With this maintenance/service offering, common wear parts are maintained or replaced.

This button is only available if the maintenance counter was activated by Apex Tool Group.

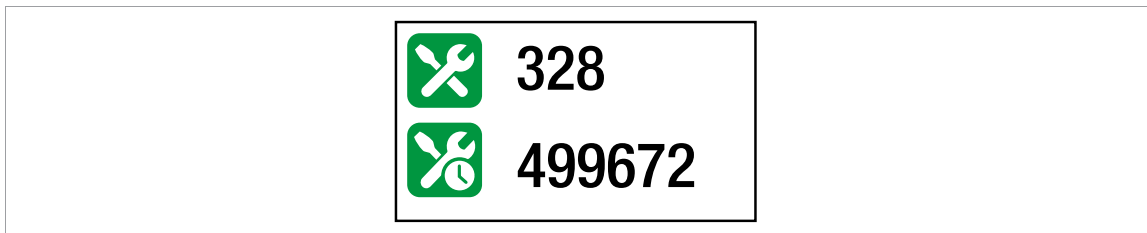



Fig. 5-29: Submenu – Maintenance counter

Button	Description
	Display of the number of rundowns under load.
	Display of the number of rundowns until the next maintenance.

### 5.9.8 Torque calibration value

In Torque calibration value, the torque calibration value of the tool can be adjusted. This may be necessary if the torque of the tool changes due to wear.

This menu is only available in the FastApps mode. In the mPro mode, the menu is hidden.

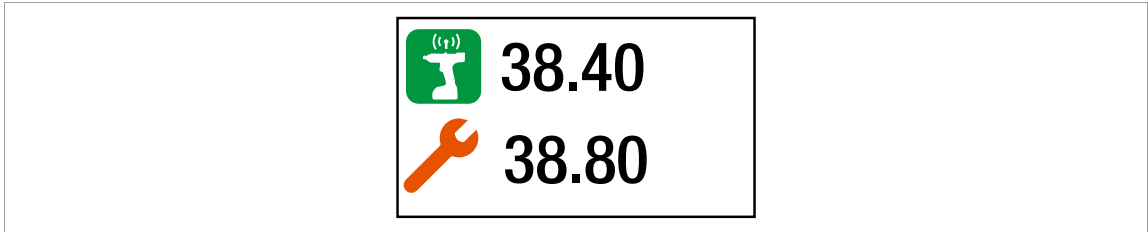

Fig. 5-30: Submenu – Torque calibration value

Button	Description
	Display of the static torque constant. This value cannot be changed.
	Display of the dynamic torque constant. This value can be changed by $\pm 20\%$ to the static torque constant.

#### Change the torque calibration value

1. Activate the input box with the button.
2. Increase/decrease the torque calibration value with the and buttons. Enter each digit of the value individually and confirm with the button. As soon as a digit is confirmed, it is stored.
3. To exit the menu, press and hold the button.

### 5.9.9 Accessory

If an accessory is used, one of the buttons is displayed depending on the type:

- 2D Reader: >
- Gyroscope: >
- Combi Accessory: >

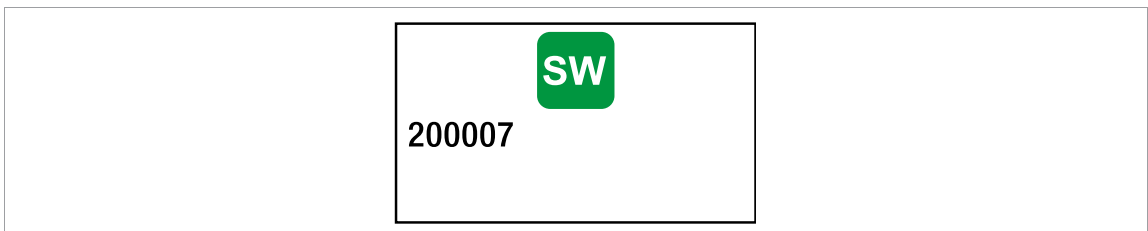







Fig. 5-31: Submenu – Accessory

Symbol	Description
	Display of the scanned barcode. The symbol is only displayed if a 2D reader is used. - No function -

Symbol	Description
	Display of the barcode type. The symbol is only displayed if a 2D reader is used. - No function -
	Display of the gyroscope angle. The symbol is only displayed if a gyroscope is used.
	Display of the software version for the accessory.
	Display of the serial number for the accessory.
	Display of the hardware version for the accessory.
	Display of the bootloader version for the accessory.

## 5.10 WLAN communication

In this menu, information about the WLAN connection is to be found. To configure WLAN settings, use the *Cordless RF Configuration* software. See document *P2372JH*.

If the tool is programmed so that WLAN settings are assigned via DHCP, this will appear to the right near the "-" symbol as long as no connection could be established.

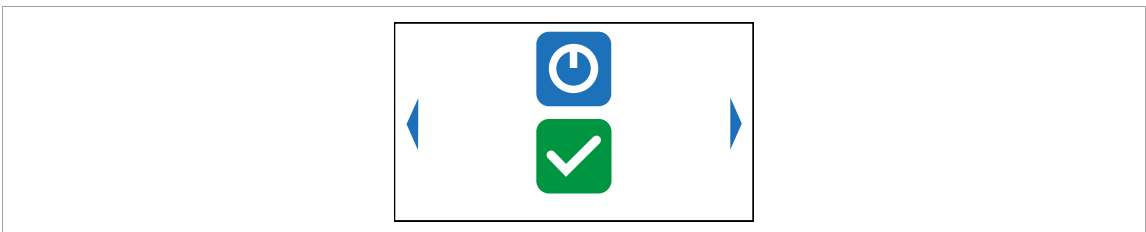













Fig. 5-32: Menu – Communications

Button	Description
	Activating/deactivating WLAN connection.

Button	Description
	SSID display.
	IP address display. If the IP address is assigned twice, the symbol  is displayed in the run screen.. ▶ Then change the IP address.
	Network mask display.
	Gateway display.
	MAC address display.
	Host name display.
	Display of the IP address of the controller that is actively connected to the tool.
	Signal strength in [dBm] display.
	EAP-TLS certificate display. The symbol is only displayed if EAP-TLS encryption is enabled.
	Region display.

### 5.10.1 Activating/deactivating WLAN connection

This menu is displayed when the WLAN connection is to be activated or deactivated.

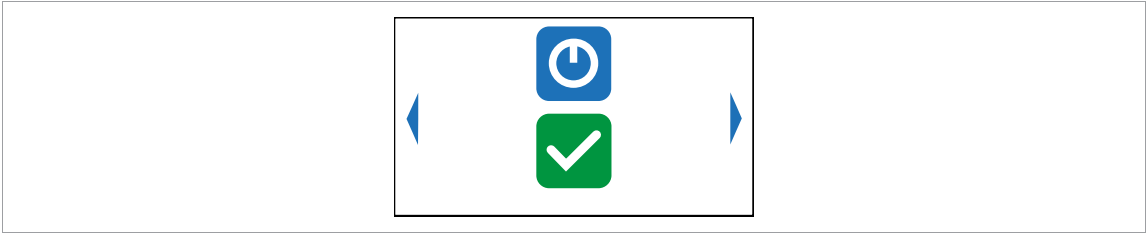







Fig. 5-33: Submenu – Activating/deactivating WLAN connection

Press the  button to switch between the following options. The visible option is active. A simultaneous WLAN and Bluetooth connection is not possible. As soon as the WLAN connection is activated, the tool disconnects the Bluetooth connection.

Button	Description
	▶ Select this button to cancel the process. Leave the menu press and hold the  button.
	▶ Select this button and confirm with the  button to activate/deactivate the WLAN connection.
	A simultaneous WLAN and Bluetooth connection is not possible. As soon as the WLAN connection is activated, the tool disconnects the Bluetooth connection.

### 5.10.2 Installing EAP-TLS certificate

The EAP-TLS certificate is used for WLAN encryption.



#### Setting up the EAP-TLS certificate on the tool

- Installing an EAP-TLS certificate on the tool. There are two ways to do this:
  - Installation via software update on the tool:  
Using the *LiveWire Cert* software to create a \*.tma file from the EAP-TLS certificate and perform a software update, see *chapter 5.12.2 Carry Out a Software Update, page 53*.
  - Installation via external software:  
Install the EAP-TLS certificate to the tool via a \*.tma file. Use the *LiveWire Cert* software for this, see document *P2521JH*.
- Parameterize EAP-TLS encryption on the tool. Use the *Cordless RF Configuration* software for this, see *P2372JH*. Configure the following WLAN settings and transfer them to the tool with <Apply>:

Parameter	Description
SSID	Enter the SSID of the WLAN network name.
Encryption	Select an 802.1x EAP-TLS encryption.
Username	Enter the username and password of the WLAN infrastructure. If not required, enter any username and password. The entry has no effect on the WLAN settings. The WLAN settings cannot be transferred to the tool if these input fields are empty.
Password	
Confirm password	



As soon as the EAP-TLS encryption is parameterized, the symbol  is displayed. The date until the EAP-TLS certificate file is valid, is displayed next to the symbol. The background color of the date indicates its status:

Color	Display	Description
White	Date	The certificate is valid. A WLAN connection to the network is possible.
White	„-“	The date of the certificate is invalid, e.g. 31.02.2020.
Yellow	Date	The expiration date has passed and the certificate is no longer valid. A WLAN connection to the network is not possible.
Red	„-“	802.1x EAP-TLS encryption has been configured via the <i>Cordless RF Configuration</i> software, but no certificate has been installed yet.

An EAP-TLS certificate file cannot be uninstalled or transferred to another tool. The EAP-TLS certificate file can only be deleted if the tool is reset to the factory settings. To use a newer certificate file, install it on the tool. The tool always uses the certificate file with the newest date.

## 5.11 Bluetooth communication

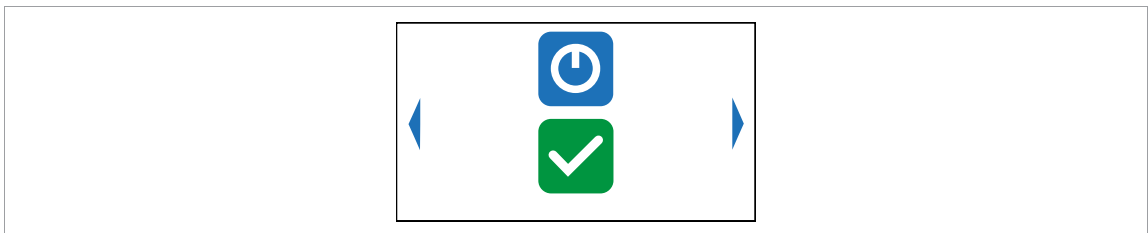









Fig. 5-34: Menu – Bluetooth communication

Button	Description
	Activating/deactivating Bluetooth.
	Scanning Bluetooth devices and establishing a Bluetooth connection.
	Display active Bluetooth connection and disconnect Bluetooth connection. ➤ The MAC address or the name of the controller is displayed with which the tool is connected via Bluetooth.

Button	Description
	<p>Select the node number.</p> <ul style="list-style-type: none"> <li>The IP address ranges from 192.168.245.101 to 192.168.245.107 and depends on the node number. Example: Tool 3 has the IP address 192.168.245.103.</li> <li>Ensure that each node number is assigned only once.</li> </ul> <p>Up to seven node numbers can be assigned:</p> <ol style="list-style-type: none"> <li>Press the  button to activate the input field.</li> <li>Use the arrow keys to increase/decrease the node number.</li> <li>Confirm with the  button. <ul style="list-style-type: none"> <li>If the node number is assigned twice, the field is highlighted in yellow and the symbol  is displayed in the run screen. In this case, change the node number.</li> </ul> </li> </ol>
	MAC address display of the Bluetooth module.

### 5.11.1 Activating/deactivating Bluetooth

This menu is displayed when Bluetooth is to be activated or deactivated.

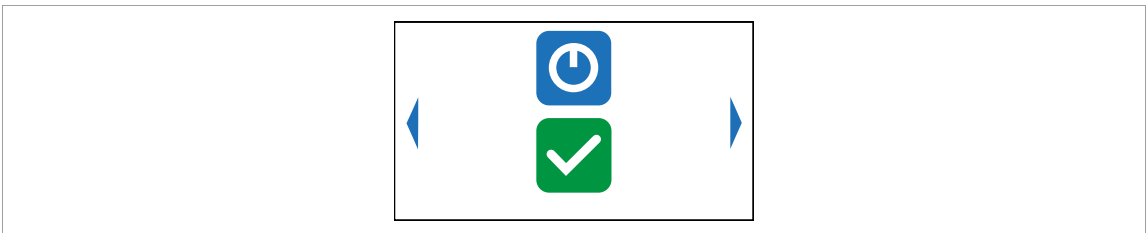







Fig. 5-35: Submenu – Activating/deactivating Bluetooth

Press the  button to switch between the following options. The visible option is active. A simultaneous WLAN and Bluetooth connection is not possible. As soon as the WLAN connection is activated, the tool disconnects the Bluetooth connection.



Button	Description
	<p>Select this button to cancel the process. Leave the menu press and hold the  button.</p>
	<p>Select this button and confirm with the  button to activate/deactivate the WLAN connection.</p>
	<p>A simultaneous WLAN and Bluetooth connection is not possible. As soon as the Bluetooth connection is activated, the tool disconnects the WLAN connection.</p>

### 5.11.2 Scanning Bluetooth devices

The scan will continue as long as the menu is open.





Fig. 5-36: Submenu – Scanning Bluetooth devices

Button	Description
	<p>List of all devices detected during scanning.</p> <ul style="list-style-type: none"> <li>All devices with which a Bluetooth connection is possible are displayed. The tool can only connect to a controller of the mPro200GC-AP series.</li> <li>Each device is displayed with an icon and the MAC address or name of the device.</li> <li>The controller to which the tool is already connected is highlighted in green in the list.</li> </ul> <p>To establish a Bluetooth connection, select a controller and confirm with the  button, see document P2545KA for details.</p> <ul style="list-style-type: none"> <li>➤ Yellow background: Connection establishment is ongoing.</li> <li>➤ Green background: Bluetooth connection has been established.</li> <li>➤ Red background: Bluetooth connection failed.</li> </ul>
	<p>Waiting time until a device is found during the scanning process.</p>

### 5.11.3 Disconnect Bluetooth connection



Fig. 5-37: Submenu – Disconnect Bluetooth connection

1. Press the  button to open the submenu with the following options. The visible option is active.
2. Press the arrow keys to switch between the options.
3. Confirm the selection with the  button.

Button	Description
	<ul style="list-style-type: none"> <li>▶ Press to cancel the process.</li> <li>➤ The Bluetooth connection to the device is not interrupted.</li> <li>➤ The <i>Disconnect Bluetooth connection</i> menu is exited.</li> </ul>

Button	Description
	<ul style="list-style-type: none"> <li>▶ Press to disconnect the Bluetooth connection.</li> <li>➤ The Bluetooth connection to the device is interrupted.</li> <li>➤ The <i>Disconnect Bluetooth connection</i> menu is exited.</li> </ul>

## 5.12 Utility

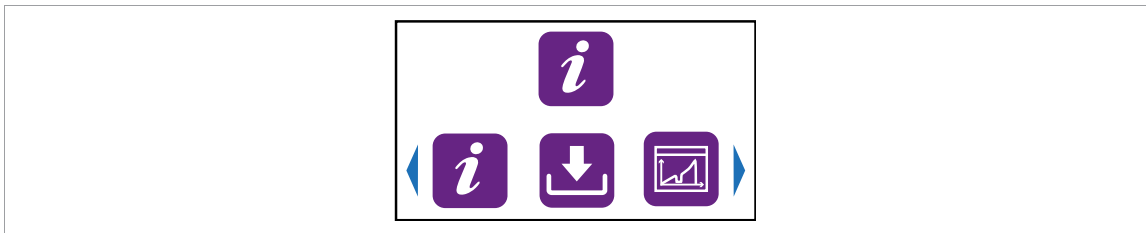





Fig. 5-38: Menu – Utility

Button	Description
	Display of the software versions.
	Reset to factory settings.
	Switch off tool.







### 5.12.1 Displaying the software version



Fig. 5-39: Submenu – Displaying the software version

- ▶ Use the arrow keys to switch between the menu items.

Symbol	Description
	Display of the software version for the measuring board.

Symbol	Description
	Display of the software version for the operating system.
	Display of the software version for the servo.
	Display of the software version for the display.
	Display of the version for the display bootstrap.
	Display of the version for the display failsafe.
	Display of the hardware version and revision. Example: 1.3 Hardware version: 1 Hardware revision: 3
	Display of the software version of mPro Connect. This symbol is only displayed if mPro Connect software is installed on the tool.

### 5.12.2 Carry Out a Software Update

Carry out the software update via a WLAN connection using the **Cordless RF Configuration software**.

1. Switch the tool on.
2. Install the *Cordless RF Configuration* software, see document *P2372JH*.
3. Make sure that the WLAN settings on the tool are configured so that the software update can be performed via a WLAN connection.
4. Activate the *TCP/IP direct* interface in the *Communication with tool* ab and enter the IP address of the tool.
5. Open the *Tool identification* tab.
6. To change the software on the tool, press <Software Update>.
7. Confirm the following messages with <ja>.
8. Select the appropriate \*.tma file with the selection dialog.



#### Note

**Do not switch off the system after software update is completed.**

The update can take up to three and a half minutes.

- Wait until the software update is completely finished. As soon as **SW update done!** is displayed, the software update starts in background.

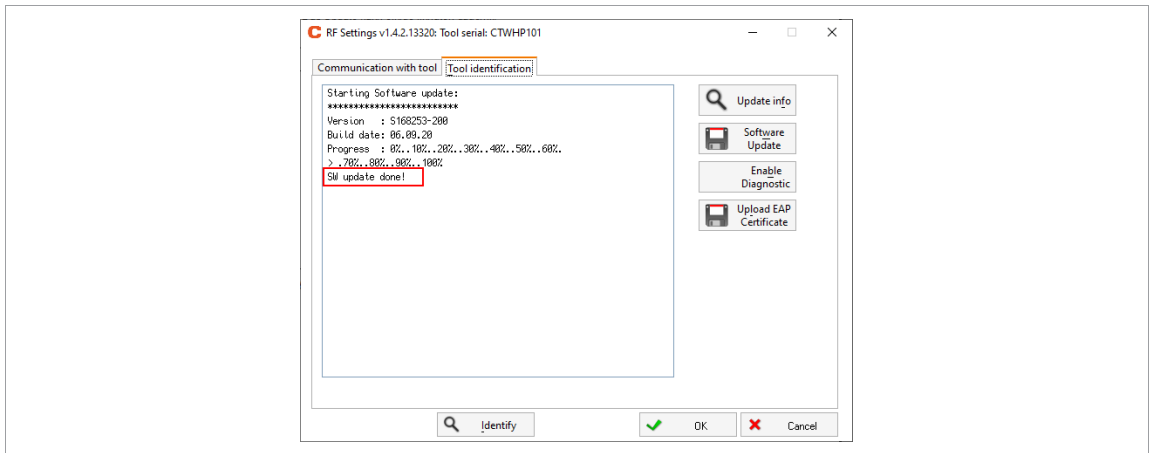

Fig. 5-40: Update process

- The software update is finished when the tool restarts.

### 5.12.3 Resetting to factory settings

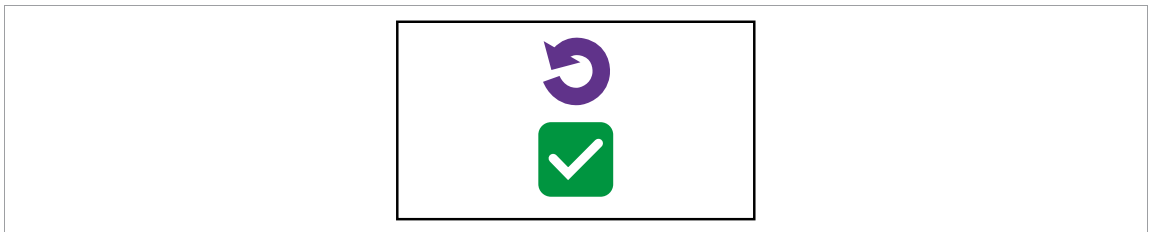





Fig. 5-41: Submenu – Resetting to factory settings

Button	Description
	<ul style="list-style-type: none"> <li>▶ Press and hold the  button to cancel the process.</li> <li>➤ The tightening results and the torque graphs are not deleted.</li> </ul>
	<ul style="list-style-type: none"> <li>▶ Press to reset the tool to factory settings.</li> <li>➤ All the settings of the tool and the archive are deleted.</li> <li>➤ The <i>Resetting to factory settings</i> menu is exited.</li> </ul>

## 6 Tightening sequence

In the FastApps mode, there is a choice between two tightening sequences:

- **Torque shutoff: Sequence 31 torque controlled, extended monitoring**

Shut-off torque-controlled tightening sequence with torque and angle check.

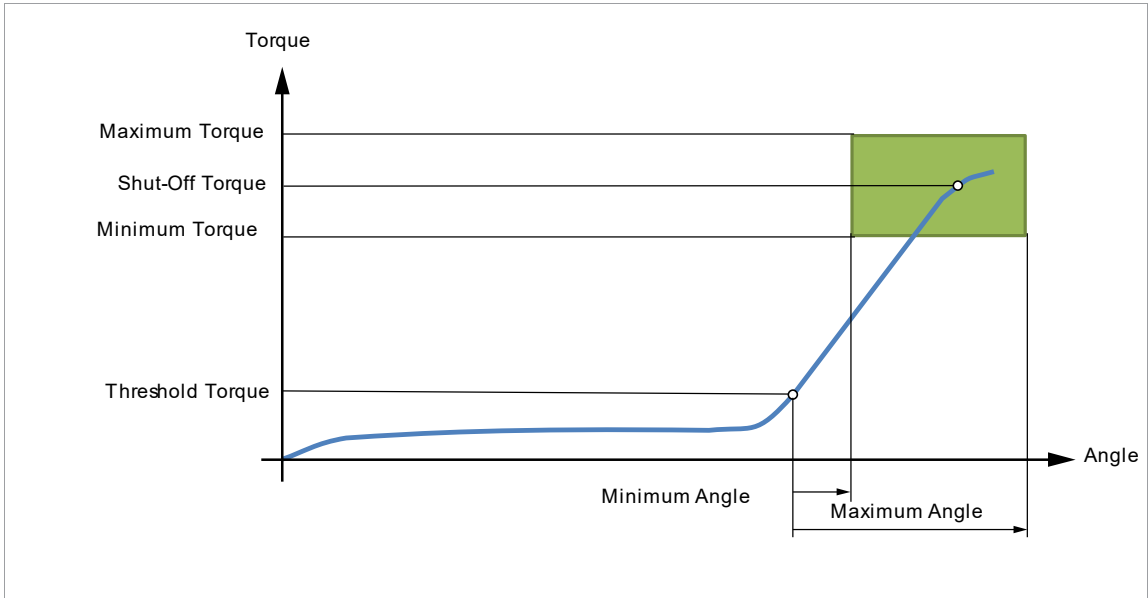

Fig. 6-1: Representation of torque shutoff

- **Angle shutoff: Sequence 51 angle-controlled, extended monitoring**

Shut-off angle-controlled tightening sequence with angle and torque check.

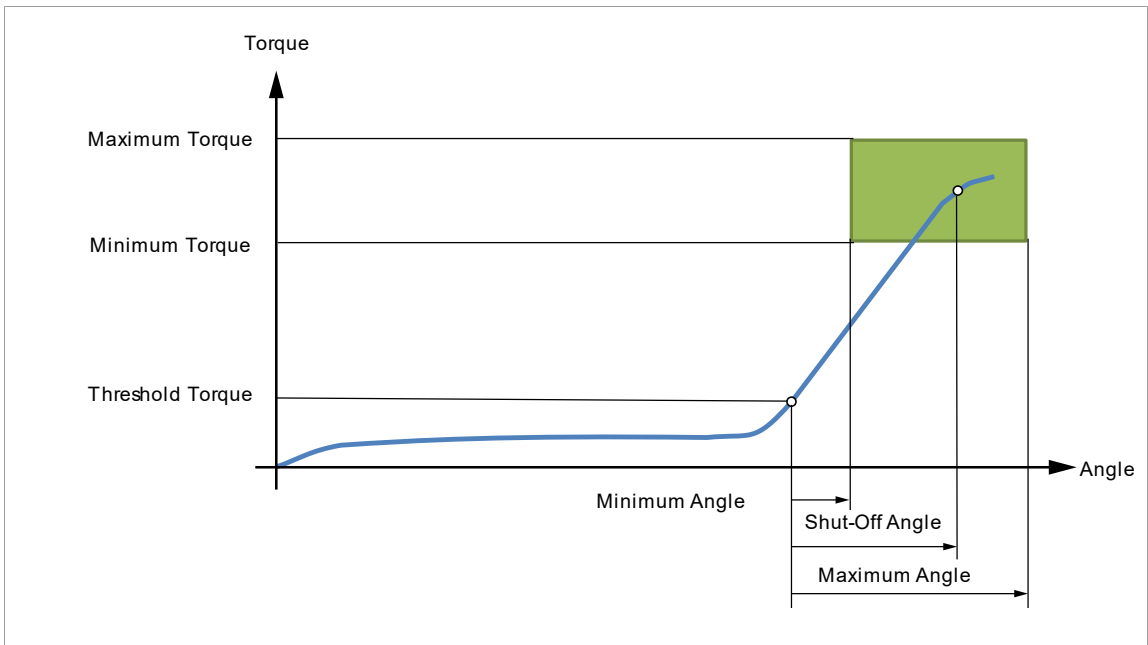

Fig. 6-2: Representation of angle shutoff

The following description applies to both tightening sequences.

For the speed, select a second speed parameter *Final Speed*. The behavior at the Final Speed is different in FastApps and mPro mode:

- FastApps mode: If the *Final Speed* is programmed, the speed immediately changes from the start speed to the final speed up to the maximum torque.
- mPro mode: If the *Final Speed* is programmed, the speed is reduced from the starting speed to the final speed starting from the threshold torque to the maximum torque.

The final speed must be lower than the standard speed.

The angle counting starts when the *Threshold Torque* is reached.

After switching off via the *Shut-Off Torque/Shut-Off Angle*, the torque that develops or the associated angle is compared with the *Minimum/Maximum Torque* and the *Minimum/Maximum Angle* and evaluated OK/NOK accordingly.

The following parameters can be programmed in the particular FastApp configuration, see *chapter 5.7 FastApps menu, page 27*.

Parameter	Description	Range of values	Abbrev.
Speed	Speed selection: In the range of the maximum speed specified in the tool constants, with validity at the beginning of the sequence up to the threshold torque (mPro mode)/Speed threshold (FastApps mode).  Begin: With tool start End: <ul style="list-style-type: none"> <li>Threshold Torque (mPro mode)</li> <li>Speed threshold (FastApps mode).</li> </ul>	± Maximum speed	n (rpm)
Speed Threshold (rpm) <sup>1</sup>	Speed when the maximum torque is reached. Must be less than the starting <i>Speed</i> sein.  <b>FastApps-Modus</b> As soon as the speed threshold is reached, the speed is reduced from the starting speed to the final speed at the maximum torque. With increasing torque, the speed drops.  Begin: From the Speed Threshold Torque Ende: Shut-Off Torque  <b>Pro mode</b> In mPro mode, the parameterization of the controller is valid.	± Maximum speed	n2
Maximum Angle	Upper limit of attained angle.	0 ... 9 999	AngMax (deg)
Maximum Torque	Upper limit of attained torque.	0 ... 1,2 x MD capacity	TqMax
Minimum Angle	Lower limit of attained angle.	0 ... 9 999	AngMin (deg)
Minimum Torque	Lower limit of attained torque.	0 ... TQ Shut-Off Torque	TqMin
Threshold Torque	Beginning of angle counting.	0 ... TQ capacity	TqTh
Shut-Off Torque	Valid monitoring torque during the tightening process. If the monitoring torque is exceeded, the drive stops immediately.	0 ... TQ capacity	TqP
Shut-Off Angle		0 ... 9 999	AP (deg)











<sup>1</sup> The maximum torque is not normally reached. The torque shutoff value is less than the maximum torque. Therefore, it is not completely regulated to the final speed.







# 7 Troubleshooting











## 7.1 Messages on the Display

### Messages shown on the runscreen

Symbol	Possible cause	Measure
	If WLAN is used, the IP address is assigned twice. If Bluetooth is used, the node number is assigned twice.	► Change the IP address. ► Change the node number.
	The tool is locked because the time, which the tool is allowed to work in offline mode, has expired.	► Reconnect the control and the tool.
	The tool is locked until a new workpiece ID or barcode is scanned.	► Scan barcode.
	The tool is locked as long as the scanned barcode is being processed.	► Wait until the barcode is processed.
	The tool is locked because there is no job for the next rundown.	► Select application/batch.
	This message appears only when a tubenut is used. With the next rundown, the tubenut opens.	► Perform the next rundown.
	The tool is locked because the barcode is expected and the time, which the tool is allowed to work in offline mode, has expired.	► Reconnect the control and the tool.
	The tool is locked because the battery has reached the undervoltage limit.	► Change the battery.
	The tool is locked because no tightening parameters are available.	► Parameterize parameters in the application/batch.
	The tool is locked because the maximum number of NIO results has been exceeded, see <i>P2280PM</i> (Reject Release).	► Use counterclockwise rotation or set <i>Reject Release</i> input.
	The tool is locked by the controller.	► Check the error message in the run screen on the controller.

### Messages shown on the display

Symbol	Possible cause	Measure
	Warning that the battery has reached the undervoltage limit. The symbol is displayed until the Linking group is completed. Then the tool is locked.	► Confirm the warning with the  key. A further message appears when the battery needs to be changed.
	Warning that the warning threshold before maintenance has been reached.	► Confirm the warning with the  key. A further message appears when the maintenance counter is reached, and the tool must be maintained.
	Warning that tightening in counterclockwise rotation is not allowed. This occurs if the option <i>Allowed After NOK</i> is selected on the control under <i>Navigator &gt; Advanced &gt; Tool Group &gt; Evaluation and Backoff &gt; Back-Off Mode for all Applications and Linking Steps</i> .	

Symbol	Possible cause	Measure
	The tool is connected to a laptop/PC via a Micro-B USB cable.	
	The tool is locked because maintenance is required.	▶ Confirm the warning with the  key and send the tool to a <i>Sales &amp; Service Center</i> for maintenance, see reverse side.
	Communication between measuring card and LCD interrupted.	▶ The tool automatically performs a re-start. Wait until the tool has re-started.
	No CID available.	▶ Insert Cleco CID.
	CID not inserted correctly.	▶ Insert Cleco CID correctly.
	No signed CID.	▶ Use Cleco CID.
	▶ CID is invalid.	
	CID is damaged.	▶ Replace CID.
	Software is not available or damaged.	▶ Perform software update.
	The software on the CID is not compatible with the hardware of the tool.	▶ Install compatible software.
	The message is displayed for tools with hardware version 2 if the software version on the CID is $\leq 220$ . In this case, the message appears every time the tool is started until compatible software is installed.	
	If the message is confirmed with the  key, the tool can still be used with the software version installed on the tool.	

## 7.2 Error messages

### Error messages for shut-off cause

Error message	Description
A<	Angle too small
A>	Angle too large
AW<	Too few graphic values recorded for an evaluation
BLOC	Tightened on block
CAL	Torque encoder calibration error
ENC	Angle encoder error
Error	Error occurred
IIT	Requested motor output is too high
IP	Error output section, excessive current
IREC	Current/TQ redundant
JUM	Error due to the socket slipping off
MBO>	Torque has exceeded top evaluation torque
MBU<	Torque has fallen below bottom evaluation torque

Error message	Description
MDSI	Safety torque exceeded
NOK	Rundown is not ok
OFF	Torque encoder offset error
OK	Rundown is ok
RC	Rundown terminated by interruption of the start signal
SS>	Max. number of cycles for stick-slip exceeded
SST	Too many stick-slip edges
TMAX	Canceled by exceeding the max. time
TQ<	Torque too low
TQ>	Torque too high
TTT<	Time that may lapse after threshold torque maximum. If this time is exceeded, there is a shut-off with this error message.
TTT>	Time that must pass in the Shut-Off Value after threshold torque minimum is reached. If the time is less, this error message is output.











**Error messages of the gyroscope**

Error message	Possible cause	Measure
GAE	Invalid angle value returned from gyroscope.	► Contact a <i>Sales &amp; Service Center</i> , see reverse.
GAEX	Tool rotated more than $\pm 180^\circ$ .	► Don't rotate tool not more than $\pm 180^\circ$ .
GARE	Tool moved too fast, angle rate too high.	► Move the tool slower while tightening.
GCOM	Internal communication error	► Check gyroscope contact. If error occurs again contact <i>Sales &amp; Service Center</i> , see reverse.
GVE	Supply voltage too high or too low	► Contact a <i>Sales &amp; Service Center</i> , see reverse.

**Error messages, software updates and data storage**

Error message	Description	Measure
E1	Export script not available.	► Try to export the script two to three times. ► If the error message continues to occur, perform a software update.
E2	Error during export.	► Insert SD card. ► Check SD card for errors.
E3	Error while writing the archive.	► Check SD card for errors.
E10	Software update script not available.	► Try two to three times to perform the software update ► If the error message continues to occur, contact a <i>Sales &amp; Service Center</i> , see reverse
E50	Crash during software update.	
E99	Timeout on startup expired.	► Insert SD card.
E110	No compatible update packages found.	► Make sure there is the right *.tma file selected.
E200	Several *.tma files available.	► Select only one *.tma file.
E210	No compatible update packages found.	► Make sure there is the right *.tma file selected.

## 7.3 Tool problems

Problem	Possible cause	Measure
Tool does not start.	No speed programmed.	<ul style="list-style-type: none"> <li>▶ Check Linking group. In the mPro mode, select <i>Navigator</i> &gt; <i>Standard</i> or <i>Navigator</i> &gt; <i>Basic</i>.</li> <li>▶ Check FastApps. In the FastApps mode:  &gt; .</li> </ul>
	Controller is waiting for tool enablement.	▶ Enable the input <i>Tool Enable</i> or, if not required, deactivate <i>Tool Enable</i> .
	Fast-Apps mode disabled.	▶ Enable FastApps mode:  >  >  .
	Self-identification data are not recognized after tool change.	Accept Tool Settings again: <ol style="list-style-type: none"> <li>1. <i>Navigator</i> &gt; <i>Tool Setup</i>.</li> <li>2. Select the line with the tool.</li> <li>3. Select <i>Tool Settings</i> &gt; <i>Accept</i>.</li> </ol>
Tool not recognized.	Software is incorrect.	▶ Check controller and measuring card software.
	FastApps mode is activated.	▶ Disable FastApps mode to connect to the controller.
	Tool is defective.	▶ Change tool.
Tool doesn't start with counterclockwise rotation activated.	With counterclockwise rotation, parameter for speed is set to 0 1/min.	Parameterize Speed left rotation <ul style="list-style-type: none"> <li>▶ Select on the controller <i>Navigator</i> &gt; <i>Standard</i> &gt; <i>Tool Groups</i> &gt; <i>Settings For Speed Left Rotation</i>.</li> </ul>
Work light disabled.	Disabled by parameter setting.	▶ Parameterize the tool light on the controller screen: <i>Navigator</i> > <i>Advanced</i> > <i>Tool Group</i> > <i>Extended Tool Settings</i> .
		▶ To activate the work light:  >  .
Tool shuts off prematurely.	Operator releases start trigger before the controller stops the tool.	▶ Make sure that the operator keeps the start trigger pressed throughout the entire sequence.
	The fastening time exceeds the standard time of 10 seconds.	▶ Increase the fastening time.
	Tool exceeds the angle setpoint.	<ul style="list-style-type: none"> <li>▶ Check the fastening sequence to ensure that the torque shutoff value and/or angle setpoint are correct. Adjust as necessary.</li> <li>▶ Check whether the fastening joint has changed significantly.</li> </ul>
Control menu on tool is not enabled or only partially enabled.	Disabled by parameter setting.	▶ To enable the control menu:  >  .
No-load speed not reached.	Battery voltage is too low.	▶ Use a fully charged battery.
Expected number of run-downs is not achieved with one charge of the battery.	Battery is not fully charged.	▶ Use fully charged battery.
	The warning threshold for undervoltage is not set to the minimum value.	<ul style="list-style-type: none"> <li>▶ Reduce the Undervoltage (V) on the control screen: <i>Navigator</i> &gt; <i>Tool Setup</i> &gt; <i>Tool Settings</i> &gt; <i>Others</i> &gt; <i>Low Level [V]</i>.</li> <li>▶ To set the warning threshold:  &gt; .</li> </ul>

Problem	Possible cause	Measure
	High torque is needed during a fastening sequence, e.g., for coated fasteners.	If a high torque is needed for a longer period of time, e.g., for several turns, the number of run-downs that can be achieved with one battery charge will be significantly reduced.
	Battery has too many charging cycles.	After 800 charging cycles, the capacity is reduced to approx. 60%.
Software does not boot.	Error in the main software.	<ul style="list-style-type: none"> <li>▶ Press the following keys:  </li> <li>▶ Use recovery SD card. Contact <i>Sales &amp; Service Center</i>, see back page.</li> </ul>
Barcode is not read.	Barcode is damaged.	▶ Use another barcode.
	Wrong barcode type is used.	▶ Use another barcode.
	Wrong barcode type is programmed.	▶ Unlock the barcode type used.

## 7.4 WLAN data communication problems





### WLAN data communication problems between controller and access point

Problem	Possible cause	Measure
No communication between the controller/service PC and access point. Applies only to WLAN infrastructure customers.	IP address and subnet mask are not in the same range.	<p>Without network administration, it is necessary for the IP address and subnet mask for the mPro200GC and the base station to be in the same range.</p> <ol style="list-style-type: none"> <li>1. Use the same subnet mask for both.</li> <li>2. For the IP address, use the same first three numbers, e.g., <ul style="list-style-type: none"> <li>- IP address for the controller: 192.168.1.xxx</li> <li>- IP address for the base station: 92.168.1.xxx</li> <li>- Subnet mask: 255.255.255.0</li> </ul> </li> </ol>

### WLAN data communication problems between tool and access point

Problem	Possible cause	Measure
The tool can not connect with the access point. Indicator: Signal strength at tool is always "-". The tool does not appear in the list of connected clients.	Tool not yet parameterized with the correct WLAN settings.	▶ Parameterize WLAN settings in the controller and with the <i>Cordless RF Configuration</i> PC software. See Document P2545KA.
	WLAN settings are different for the tool and the access point.	▶ Use the <i>Cordless RF Configuration</i> PC software to check whether the WLAN settings for the tool match the settings of the access point (SSID, encryption, network key).
	Encryption settings are not selected correctly. Password is entered incorrectly.	
	Incorrect WLAN channel	Select another channel.  <ol style="list-style-type: none"> <li>1. Select the channel on the controller: <i>Utility &gt; Cordless Tools</i>.</li> <li>2. Select the channel with the <i>Cordless RF Configuration</i> PC software. The same channel must be set as on the controller.</li> </ol>

## WLAN data communication problems between controller and tool

Problem	Possible cause	Measure
No WLAN data communication between the controller and tool.	The IP address of the tool is not correctly entered in the controller.	<ol style="list-style-type: none"> <li>1. Check on the control screen: <i>Navigator &gt; Tool Setup</i>, whether the IP address of the tool has been entered in the box <i>Type</i>.</li> <li>2. Otherwise, mark the line and &lt;Edit&gt;.</li> </ol> <p>IP address of tool – see Tool in submenu <i>WLAN communication</i>.</p>
	Tool is already assigned to another controller.	<ul style="list-style-type: none"> <li>▶ Check the WLAN settings and make sure that the WLAN settings for the controllers are different.</li> </ul> <p>Applies only to WLAN infrastructure customers:</p> <ul style="list-style-type: none"> <li>▶ Check whether another controller already has a connection to this tool. In other words, another controller is using the same IP address.</li> </ul>
IP address cannot be pinged.	IP address already exists in the network. In this case, the tool will not establish a connection.	<ul style="list-style-type: none"> <li>▶ Check the physical connection (RSSI values):  &gt; </li> <li>▶ Check the assigned IP address.</li> </ul>
Occasional interruptions in WLAN data communication.	Distance between the access point and the tool is too great.	<ol style="list-style-type: none"> <li>1. Check signal strength at tool in the submenu <i>Signal Strength</i>:  &gt; </li> <li>2. If necessary, reduce the distance between the access point and the tool.</li> </ol>
	Excessive data traffic on WLAN network.	<p>Reduce data traffic on WLAN network.</p> <ol style="list-style-type: none"> <li>1. On the Basic control screen, increase the Trigger: <i>Navigator &gt; Basic Application Builder &gt; Trigger Torque</i>.</li> <li>2. Disable the torque graph data transmission on <i>Navigator &gt; Advanced &gt; Controller &gt; General &gt; Trace Recording</i>. For this, select the entry <i>Record</i> in the column <i>Off</i>.</li> </ol>

## 7.5 Bluetooth data communication problems

### Bluetooth data communication problems between controller and tool

Problem	Possible cause	Measure
The tool can not connect with the controller.	Controller is not visible.	<ul style="list-style-type: none"> <li>▶ Make sure that the Bluetooth function is activated on the controller.</li> </ul>
	The controller is not displayed in the <i>Scanning Bluetooth devices</i> menu.	<ul style="list-style-type: none"> <li>▶ Make sure that the Bluetooth function is activated on the controller.</li> <li>▶ Check that the controller is visible with another tool.</li> </ul>
	Establishing a Bluetooth connection fails.	<ul style="list-style-type: none"> <li>▶ Note that the tool can only connect to an mPro200GC series controller.</li> <li>▶ Retry to establish a Bluetooth connection.</li> <li>▶ Restart the tool and try to establish the Bluetooth connection again.</li> <li>▶ Restart the controller and try to establish the Bluetooth connection again.</li> </ul>
	The node number is assigned twice.	<ul style="list-style-type: none"> <li>▶ Make sure that each node number is assigned only once. Note that only seven nodes are possible.</li> </ul>
	The wrong IP address is used for the tool on the controller.	<ul style="list-style-type: none"> <li>▶ Make sure that the tool has been installed on the controller with the correct IP address.</li> </ul>

# Index

## **2**

2D Reader .....45

## **A**

Access point .....15  
 Accessory .....45  
 Advanced settings .....31  
 AN.....6  
 Angle  
 maximum .....32  
 minimum .....32  
 angle shutoff .....29  
 Angle shutoff.....31, 55  
 Angle test.....41  
 App .....6

## **B**

Batch .....29  
 Block Angle Detection.....30  
 Bluetooth  
 activate .....50  
 connect .....49  
 deactivate .....50  
 disconnect .....51  
 scan .....51

## **C**

Calibration value .....43  
 Change mode .....21  
 CID .....21  
 change .....10  
 Confirmation button .....7  
 Counterclockwise rotation.....26  
 Counters status.....44

## **D**

Date .....34  
 Diagnostics .....39  
 Direction of rotation.....28, 30

## **E**

EAP-TLS certificate .....48  
 EAP-TLS certificate .....47  
 Error message  
 data storage.....59  
 gyroscope .....59  
 Shut-off cause .....58  
 software update .....59

## **F**

Factory settings .....54  
 FastApps  
 configure .....28  
 lock .....39

menu .....27  
 reset .....32  
 select.....25  
 FastApps mode .....7, 21, 24, 27  
 Final Speed .....32

## **G**

Gateway .....47  
 Gyroscope .....45

## **H**

Hardware version .....53  
 Host name .....47

## **I**

Install tool .....19  
 IP address .....47  
 controller .....47  
 twice .....47

## **L**

Linking group.....39

## **M**

MAC address .....47  
 MAC adresse .....50  
 Maintenance counter .....44  
 Menu lock.....39  
 mPro Connect .....53  
 mPro mode.....7, 21, 24, 27

## **N**

Navigation buttons .....7  
 Network mask .....47  
 Node number .....50  
 NOK .....6

## **O**

OK.....6

## **P**

Parameter  
 change .....20  
 PIN .....37  
 change .....38  
 deactivate.....38  
 enter .....37

## **R**

reset .....54  
 Run screen.....24

## **S**

Screen brightness .....34

Selecting button .....	20	maximum.....	31
Settings.....	33	minimum.....	31
Shut-off properties .....	36	unit .....	36
Signal strength.....	47	Torque calibration value .....	45
Software update.....	53	torque shutoff .....	29
Software version .....	52	Torque shutoff .....	31, 55
Speed		Torque test.....	42
Final Speed .....	32	TQ .....	6
Speed Threshold .....	32	TQ calibration value .....	45
Speed test .....	41		
SSID .....	47	<b>U</b>	
Start Speed.....	29	Undervoltage limit .....	43
Status indication .....	25	USB connection .....	8
Switch off .....	52	Utility .....	52
Switching off .....	20		
Switching on .....	20	<b>V</b>	
System layout .....	10	Voltage.....	43
<b>T</b>		<b>W</b>	
Threshold Torque .....	29, 32	WLAN AP Configuration.....	15
Tightening sequence .....	55	WLAN connection	
Tightening strategy .....	31	activate.....	48
Time.....	34	deactivate.....	48
Tool data.....	11	WLAN setting .....	17
Tool light .....	35		
Torque			





# POWER TOOLS SALES & SERVICE CENTERS

Please note that all locations may not service all products.

Contact the nearest Cleco® Sales & Service Center for the appropriate facility to handle your service requirements.

 Sales Center

 Service Center

## NORTH AMERICA | SOUTH AMERICA

### DETROIT, MICHIGAN

Apex Tool Group  
2630 Superior Court  
Auburn Hills, MI 48236  
Phone: +1 (248) 393-5644  
Fax: +1 (248) 391-6295

### LEXINGTON,

#### SOUTH CAROLINA

Apex Tool Group  
670 Industrial Drive  
Lexington, SC 29072  
Phone: +1 (800) 845-5629  
Phone: +1 (919) 387-0099  
Fax: +1 (803) 358-7681

### MEXICO

Apex Tool Group  
Vialidad El Pueblito #103  
Parque Industrial Querétaro  
Querétaro, QRO 76220  
Mexico  
Phone: +52 (442) 211 3800  
Fax: +52 (800) 685 5560

## EUROPE | MIDDLE EAST | AFRICA

### ENGLAND

Apex Tool Group UK  
C/O Spline Gauges  
Piccadilly, Tamworth  
Staffordshire B78 2ER  
United Kingdom  
Phone: +44 1827 8727 71  
Fax: +44 1827 8741 28

### FRANCE

Apex Tool Group SAS  
25 Avenue Maurice Chevalier - ZI  
77330 Ozoir-La-Ferrière  
France  
Phone: +33 1 64 43 22 00  
Fax: +33 1 64 43 17 17

### GERMANY

Apex Tool Group GmbH  
Industriestraße 1  
73463 Westhausen  
Germany  
Phone: +49 (0) 73 63 81 0  
Fax: +49 (0) 73 63 81 222

### HUNGARY

Apex Tool Group  
Hungária Kft.  
Platánfa u. 2  
9027 GyőrHungary  
Phone: +36 96 66 1383  
Fax: +36 96 66 1135

## ASIA PACIFIC

### AUSTRALIA

Apex Tool Group  
519 Nurigong Street, Albury  
NSW 2640  
Australia  
Phone: +61 2 6058 0300

### CHINA

Apex Power Tool Trading  
(Shanghai) Co., Ltd.  
2nd Floor, Area C  
177 Bi Bo Road  
Pu Dong New Area, Shanghai  
China 201203 P.R.C.  
Phone: +86 21 60880320  
Fax: +86 21 60880298

### INDIA

Apex Power Tool Trading  
Private Limited  
Gala No. 1, Plot No. 5  
S. No. 234, 235 & 245  
Indialand Global  
Industrial Park  
Taluka-Mulsi, Phase I  
Hinjawadi, Pune 411057  
Maharashtra, India  
Phone: +91 020 66761111

### JAPAN

Apex Tool Group Japan  
Korin-Kaikan 5F,  
3-6-23 Shibakoen, Minato-Ku,  
Tokyo 105-0011, JAPAN  
Phone: +81-3-6450-1840  
Fax: +81-3-6450-1841

### KOREA

Apex Tool Group Korea  
#1503, Hibrand Living Bldg.,  
215 Yangjae-dong,  
Seocho-gu, Seoul 137-924,  
Korea  
Phone: +82-2-2155-0250  
Fax: +82-2-2155-0252

**Cleco**<sup>®</sup>  
Production Tools

**Apex Tool Group, LLC**  
Phone: +1 (800) 845-5629  
Phone: +1 (919) 387-0099  
Fax: +1 (803) 358-7681  
[www.ClecoTools.com](http://www.ClecoTools.com)  
[www.ClecoTools.de](http://www.ClecoTools.de)