



Parts Manual
 PL16-5187-LG1
 03/15/2018

MP5187
 Needle Scaler / Chipping Hammer



Model Number	Blows per Minute	Bore		Stroke		Length		Weight		Hose ID		Air Inlet
		in.	mm	in.	mm	in.	mm	lbs.	Kg	in.	mm	
MP5187	4,200	0.79	20	0.59	15	8.9	225	2.5	1.1	1/4"	6.4	1/4"

For additional product information visit our website at <http://www.ClecoTools.com>

Manufacturer:

Apex Tool Group, LLC
670 Industrial Drive
Lexington, South Carolina 29072, USA

Importer:

Apex Tool Group GmbH
Industriestraße 1
D-73463 Westhausen, Germany

For this Instruction Manual

The original language of this instruction manual is English. This Instruction Manual is intended for all persons who will operate and maintain this equipment.

Symbols on product

Be sure you understand their meaning before using this equipment.



Read all instructions



Eye protection must be worn at all times during the operation or maintenance of this tool.



Ear protection must be worn at all times during the operation or maintenance of this tool.



CE compliant

1 Safety:

WARNING! Indicates a potentially **hazardous** situation for personal health and safety. If this warning is not observed, death or serious injury may occur.



CAUTION! Indicates a potentially **hazardous** situation which, if not avoided, may result in minor or moderate injury or property and environmental damage.



Speed check

Using a tachometer, check the tool speed weekly or with every 200 hours of operation to assure it does not exceed the rated speed of the tool at 90 psig.

Personal protective equipment

WARNING!



Exercise caution, pay attention to what you are doing and act reasonably at all times when working with a pneumatic tool. Never use a pneumatic tool while under the influence of drugs, alcohol or medication. One moment of inattentiveness in the use of a pneumatic tool can cause serious injuries.

General Safety Instructions

Designated Use

This pneumatic tool is to be used only for removing material by utilizing appropriate cutting devices.

Do not modify the tool, any guard, or accessory unless approved in writing by Apex Tool Group, LLC.

WARNING!



Any abuse or misuse of this tool or the abrasive can be extremely dangerous. The abrasive used with this tool are not manufactured or supplied by Apex Tool Group, LLC. Consult and comply with the safety practices provided by the abrasive manufacturer.

Air Line Lubrication:

Part No.	Packaged	Designation
540397	1 Quart (0.94 liter)	Airlube 10W/NR-420LB DR
533485	1 US Gallon (3.78 liter)	Airlube 10W/NR-420LB DR

Air Supply Line:

Parameter	Description
Air Hose	Minimum inside diameter: 1/4" (6.35mm) Maximum length: 8.0' (2.4 m)
Working pressure range	Performance rated at: 90 psi (620 kPa)
Compressed air	Air quality according to ISO 8573-1, quality class 2.4.3 The compressed air must be clean and dry.

Disposal:



Observe local disposal guidelines for all components of this tool and its packaging.

Copyright protection:

Apex Tool Group, LLC reserves the right to modify, supplement or improve this document or the product without prior notice. This document may not be reproduced in any way, shape or form, in full or parts thereof, or copied to another natural or machine readable language or to a data carrier, whether electronic, mechanical, optical or otherwise without the express permission of Apex Tool Group, LLC.

Hersteller:

Apex Tool Group, LLC
670 Industrial Drive
Lexington, South Carolina 29072, USA

Importeur:

Apex Tool Group GmbH
Industriestraße 1
D-73463 Westhausen, Germany

Zu dieser Bedienungsanleitung

Diese Bedienungsanleitung ist im Original in englischer Sprache verfasst. Diese Bedienungsanleitung richtet sich an alle Personen, die an der Bedienung und Wartung dieses Geräts beteiligt sind

Symbole auf dem Produkt

Bevor Sie das Produkt verwenden, müssen Sie die Bedeutung dieser Symbole verstanden haben.



Lesen Sie alle Anweisungen durch.



Bei der Benutzung oder Wartung dieses Werkzeugs muss stets Augenschutz getragen werden.



Bei der Benutzung oder Wartung dieses Werkzeugs muss stets Ohrschutz getragen werden.



CE-konform

1 Sicherheit

WARNUNG Weist auf eine mögliche **Gefahr** für die Gesundheit hin. Wird diese Warnung nicht beachtet, kann dies zum Tod oder schweren Verletzungen führen.



VORSICHT Weist auf eine mögliche **Gefahr** hin, die – falls nicht vermieden – zu leichten oder mittelschweren Verletzungen oder Sach- und Umweltschäden führen kann.



Drehzahlprüfung

Prüfen Sie die Drehzahl des Werkzeugs wöchentlich oder alle 200 Betriebsstunden mit einem Drehzahlmesser, um sicherzustellen, dass es bei 90 psig seine Nenndrehzahl nicht überschreitet.

Persönliche Schutzausrüstung

WARNUNG



Gehen Sie bei der Arbeit mit Druckluftwerkzeugen immer vorsichtig vor, achten Sie auf das, was Sie tun, und handeln Sie stets verantwortungsvoll. Verwenden Sie ein Druckluftwerkzeug niemals unter dem Einfluss von Drogen, Alkohol oder Medikamenten. Bei der Nutzung von Druckluftwerkzeugen kann ein kurzer Moment der Unaufmerksamkeit schwere Verletzungen zur Folge haben.

Allgemeine Sicherheitshinweise

Bestimmungsgemäßer Gebrauch

Dieses pneumatische Werkzeug soll nur zum Entfernen von Material verwendet werden, indem geeignete Schneidvorrichtungen verwendet werden.

Nehmen Sie keine Änderungen an Werkzeug, Schutzvorrichtungen oder Zubehörteilen ohne schriftliche Genehmigung von Apex Tool Group, LLC vor.

WARNUNG



Jede Art von missbräuchlicher Verwendung oder Missbrauch dieses Werkzeugs kann extrem gefährlich sein. Die mit diesem Werkzeug verwendeten Schleifmittel werden nicht von Apex Tool Group, LLC hergestellt. Beachten und befolgen Sie die vom Schleifmittelhersteller vorgegebenen Sicherheitsmaßnahmen.

Schmierung der Druckluftleitung:

Teile-Nr.	Verpackt	Bezeichnung
540397	0,94 Liter	Airlube 10W/NR-420LB DR
533485	3,78 Liter	Airlube 10W/NR-420LB DR

Druckluftzufuhr:

Parameter	Beschreibung
Druckluftleitung	Min. Innendurchmesser: 1/4"(6,35mm) Max. Länge: 2,4 m
Arbeitsdruckbereich	Leistungseinstufung mit: 6,2 bar
Druckluft	Luftqualität gemäß ISO 8573-1, Qualitätsklasse 2.4.3 Die Druckluft muss sauber und trocken sein.

Entsorgung:



Bei der Entsorgung aller Komponenten dieses Werkzeugs und der Verpackung sind die vor Ort geltenden Entsorgungsvorschriften zu beachten.

Urheberschutz:

Die Apex Tool Group, LLC behält sich das Recht für dieses Dokument ohne Vorankündigung zu modifizieren, zu ergänzen oder zu verbessern. Ohne die ausdrückliche Erlaubnis der Apex Tool Group, LLC darf dieses Dokument, ob vollständig oder in Teilen, in keinsten Weise, weder in der Form oder dem Layout, reproduziert oder in eine andere natürliche oder maschinenlesbare Sprache oder auf einen Datenträger, egal ob elektronisch, mechanisch, optisch oder sonstiges kopiert werden.

Fabricant:

Apex Tool Group, LLC
670 Industrial Drive
Lexington, South Carolina 29072, USA

Importateur:

Apex Tool Group GmbH
Industriestraße 1
D-73463 Westhausen, Germany

À propos du présent manuel d'utilisation

La langue d'origine de ce manuel est l'anglais. Le présent manuel d'utilisation est destiné à toutes les personnes qui vont utiliser et entretenir ce matériel.

Pictogrammes apposés sur les produits

Assurez-vous de bien comprendre leur signification avant d'utiliser ce matériel.



Lire attentivement toutes les instructions.



Il est indispensable de porter des lunettes de protection pendant toute la durée d'opération et de maintenance de cet outil.



Il est essentiel de porter des protections auditives pendant toute la durée de l'opération et l'entretien de cet outil.



Conforme aux normes CE

1 Sécurité:

AVERTISSEMENT



Indique une situation potentiellement **dangereuse** pour la santé ou la sécurité des personnes. Le non-respect de cet avertissement peut entraîner des blessures extrêmement graves

ATTENTION



Situation potentiellement **nuisible** pour la santé des personnes ou pour le matériel et l'environnement.

Contrôle de la vitesse

À l'aide d'un tachymètre, vérifier la vitesse de l'outil chaque semaine ou toutes les 200 heures de service afin de s'assurer que la vitesse mesurée de l'outil est bien à la pression de 90 psig.

Équipement de protection personnel

AVERTISSEMENT



Soyez vigilant et attentif à ce que vous faites et agissez de manière raisonnable à tout moment lorsque vous travaillez avec un outil pneumatique. N'utilisez jamais d'outil pneumatique lorsque vous êtes sous l'emprise de drogues, d'alcool ou de médicaments. Un moment d'inattention dans l'utilisation d'un outil pneumatique peut provoquer des blessures graves.

Consignes générales de sécurité

Utilisation conforme

Cet outil pneumatique doit être utilisé uniquement pour éliminer le matériau en utilisant des dispositifs de coupe appropriés.

Ne pas modifier l'outil, tout dispositif de protection ou accessoires, sauf approbation écrite par Apex Tool Group LLC.

AVERTISSEMENT



Tout excès ou mauvais usage de cet outil ou des abrasifs peut être extrêmement dangereux. Les abrasifs utilisés sur cet outil ne sont pas fabriqués ni fournis par Apex Tool Group, LLC. Lire attentivement et se conformer aux instructions de sécurité fournies par le fabricant d'abrasifs.

Lubrification des conduites d'air :

Réf.	Quantité emballée	Désignation
540397	1 grande bouteille (0,94 litre)	Airlube 10W/NR-420LB DR
533485	1 gallon US (3,78 litres)	Airlube 10W/NR-420LB DR

Conduite d'alimentation en air :

Paramètre	Description
Tuyau d'air	Diamètre intérieur minimal : 1/4" (6,35mm) Longueur maximale : 8,0' (2,4 m)
Plage de pression de fonctionnement	Performances nominales : 90 psi (6,2 bar)
Air comprimé	Qualité de l'air conforme à ISO 8573-1, classe de qualité 2.4.3 L'air comprimé doit être propre et sec.

Mise au rebut :



Respectez toutes les directives locales de mise au rebut pour tous les composants et l'emballage de cet outil.

Protection du copyright :

Apex Tool Group, LLC se réserve le droit d'apporter des modifications, des ajouts ou des améliorations au présent document ou au présent produit, sans préavis. Le présent document ne peut être reproduit, en tout ou en partie, sous quelque forme et par quelque procédé que ce soit, ni copié dans tout autre langage naturel ou assimilable par une machine, ni sur quelque support de données, qu'il soit électronique, mécanique, optique ou autre, sans le consentement exprès d'Apex Tool Group, LLC.

Fabricante:

Apex Tool Group, LLC
670 Industrial Drive
Lexington, South Carolina 29072, USA

Importador:

Apex Tool Group GmbH
Industriestraße 1
D-73463 Westhausen, Germany

Sobre este manual de instrucciones

El idioma original de este manual de instrucciones es el inglés. Este manual de instrucciones está dirigido a todas las personas que manejan y realizan el mantenimiento de este equipo.

Símbolos en el producto

Asegúrese de haber comprendido su significado antes de utilizar este equipo.



Lea todas las instrucciones



Se debe utilizar en todo momento protección ocular durante el funcionamiento o el mantenimiento de esta herramienta.



Se debe utilizar en todo momento protección oído durante el funcionamiento o el mantenimiento de esta herramienta.



Conforme con CE

1 Seguridad:

ADVERTENCIA



Indica una situación potencialmente **peligrosa** para la salud de las personas. La inobservancia de esta advertencia puede conllevar lesiones muy graves e incluso mortales.

ATENCIÓN



Situación posiblemente **nociva** para la salud de las personas o daños materiales y medioambientales.

Comprobación de velocidad

Utilizando un tacómetro, compruebe la velocidad de la herramienta cada semana o cada 200 horas de funcionamiento para asegurarse de que no supere la velocidad nominal a 90 psig.

Equipo de protección personal

ADVERTENCIA



Tenga cuidado, preste atención a lo que esté haciendo y actúe de forma razonable en todo momento cuando utilice una herramienta neumática. No utilice nunca una herramienta neumática cuando se encuentre bajo los efectos de alguna droga, alcohol o medicamento. Una falta de atención momentánea durante la utilización de una herramienta neumática puede ocasionar lesiones graves.

Instrucciones generales de seguridad

Empleo conforme al uso previsto

Esta herramienta neumática debe utilizarse únicamente para retirar material utilizando dispositivos de corte apropiados.

No modifique la herramienta ni ninguna protección o accesorio, salvo en caso de contar con la aprobación expresa por escrito de Apex Tool Group LLC.

ADVERTENCIA



Cualquier uso abusivo o inadecuado de esta herramienta o de los abrasivos puede resultar extremadamente peligroso. Los abrasivos utilizados con esta herramienta no los fabrica ni suministra Apex Tool Group, LLC. Consulte y siga las prácticas de seguridad indicadas por el fabricante de los abrasivos.

Lubricación de la línea de aire:

Nº de parte	Envase	Designación
540397	1 cuarto de galón (0,94 litros)	Airlube 10W/NR-420LB DR
533485	1 galón de EE.UU. (3,78 litros)	Airlube 10W/NR-420LB DR

Línea de aire comprimido:

Parámetro	Descripción
Manguera de aire	Diámetro interno mínimo: 1/4" (6,35mm) Longitud máxima: 8 pies (2.4 m)
Rango de presiones de servicio	Rendimiento con: 90 libras/pulg ² (6.2 bar)
Aire comprimido	Calidad del aire según ISO 8573-1, clase de calidad 2.4.3 El aire comprimido debe estar limpio y seco.

Desecho:



Desechar los componentes y el embalaje de esta herramienta según las normas municipales vigentes.

Protección del copyright:

Apex Tool Group, LLC se reserva el derecho a modificar y realizar añadidos o mejoras en este documento o en el producto sin aviso previo. Está prohibido reproducir o transferir total o parcialmente este documento a otro lenguaje natural o legible por medios mecánicos o a soportes informáticos, ya sea de manera electrónica, mecánica, óptica o de cualquier otra forma sin el consentimiento expreso de Apex Tool Group, LLC.

Fabricante:

Apex Tool Group, LLC
670 Industrial Drive
Lexington, South Carolina 29072, USA

Importador:

Apex Tool Group GmbH
Industriestraße 1
D-73463 Westhausen, Germany

Para este manual de instruções

A língua original deste manual de instruções é o inglês. Este manual de instruções é direcionado a todas as pessoas que irão operar e fazer a manutenção deste equipamento.

Símbolos no produto

Assegure-se de compreender seu significado antes de usar este equipamento.



Leia todas as instruções



A proteção para os olhos deve ser usada durante todo o tempo de operação e manutenção desta ferramenta.



A proteção para os ouvidos deve ser usada durante todo o tempo de operação e manutenção desta ferramenta.



Segue normas CE

1 Segurança:

ATENÇÃO Indica uma situação potencialmente **perigosa** para a saúde e a segurança. Se este aviso não for observado, morte ou lesões graves podem ocorrer.



CUIDADO Indica uma situação potencialmente **perigosa** que, se não evitada, pode resultar em lesão de leve a moderada ou danos materiais ou ambientais.



Controle da velocidade

Utilizando um tacômetro, checar a velocidade da ferramenta semanalmente ou a cada 200 horas de operação para assegurar que a velocidade nominal de 90 psig não é ultrapassada.

Equipamento de proteção pessoal

ATENÇÃO



É necessário ser cauteloso, prestar atenção no que está fazendo e agir com sensatez em todos os momentos ao trabalhar com uma ferramenta elétrica. Jamais usar uma ferramenta pneumática sob influência de drogas, álcool ou medicamentos. Um momento de desatenção ao usar uma ferramenta pneumática pode causar sérias lesões.

Instruções gerais de segurança

Utilização conforme a destinação

Esta ferramenta pneumática deve ser utilizada apenas para remover material utilizando dispositivos de corte apropriados.

Não modificar a ferramenta, qualquer proteção ou acessório, exceto se aprovado por escrito pela Apex Tool Group LLC.

ATENÇÃO



Qualquer abuso ou mau uso dessa ferramenta ou do abrasivo pode ser extremamente perigoso. Os abrasivos utilizados com esta ferramenta não são manufaturados ou fornecidos pela Apex Tool Group, LLC. Consulte e siga as práticas de segurança fornecidas pelo fabricante do abrasivo.

Lubrificação dos dutos de ar:

Peça Nº.	Tamanho da embalagem	Designação
540397	0,94 Litros (1/4 galão US)	Airlube 10W/NR-420LB DR
533485	3,78 Litros (1 galão US)	Airlube 10W/NR-420LB DR

Duto de suprimento de ar:

Parâmetro	Descrição
Mangueira de ar	Diâmetro interno mínimo: 6,35 mm (1/4") Comprimento máximo: 2,4 m (8,0 pés)
Gama da pressão de trabalho	Desempenho classificado em: 6,2 bar (90 psi)
Ar comprimido	Qualidade do ar de acordo com ISO 8573-1, qualidade de classe 2.4.3 O ar comprimido tem que estar limpo e seco.

Descarte:



Siga todas as directivas locais de descarte para todos os componentes desta ferramenta e sua embalagem.

Proteção dos direitos autorais:

Apex Tool Group, LLC, reserva-se o direito de modificar, complementar ou melhorar o presente documento ou o produto sem aviso prévio. O presente documento não pode ser reproduzido de nenhuma forma, em seu todo ou parcialmente, ou copiado para outra linguagem de leitura natural ou por máquina ou para um suporte de dados, seja eletrônico, mecânico, ótico ou outro, sem a autorização expressa por escrito da Apex Tool Group, LLC.

Fabbricante:

Apex Tool Group, LLC
670 Industrial Drive
Lexington, South Carolina 29072, USA

Importatore:

Apex Tool Group GmbH
Industriestraße 1
D-73463 Westhausen, Germany

Per le presenti Istruzioni d'uso

La lingua originale delle presenti istruzioni per l'uso è l'inglese. Il presente manuale di istruzioni è destinato a tutto il personale che si occupa dell'utilizzo e della manutenzione di questo equipaggiamento

Simboli sul prodotto

Accertarsi di aver compreso il significato di questi simboli prima di usare l'attrezzatura.



Leggere tutte le istruzioni



Indossare sempre le protezioni per gli occhi mentre l'utensile è in funzione o durante gli interventi di manutenzione.



Indossare sempre le protezioni per gli orecchi mentre l'utensile è in funzione o durante gli interventi di manutenzione.



Conformità CE

1 Sicurezza:

AVVERTENZA



Indica una situazione potenzialmente **pericolosa** per la salute e la sicurezza delle persone. Se questo avvertimento non viene rispettato, si possono verificare lesioni gravi o mortali.

ATTENZIONE



Indica una situazione potenzialmente **pericolosa** che, se non evitata, può comportare lesioni di lieve o moderata entità, oppure provocare danni materiali e ambientali.

Controllo della velocità

Mediante un tachimetro, controllare ogni settimana o ogni 200 ore di esercizio la velocità dell'utensile, per assicurarsi che non superi la velocità nominale utensile di 90 psig.

Dispositivi di protezione individuale

AVVERTENZA



Procedere con cautela, prestare attenzione a quello che si sta facendo e agire in modo ragionevole in qualunque momento si stia utilizzando un utensile pneumatico. Non utilizzare mai un utensile pneumatico qualora ci si trovi sotto l'influenza di droghe, alcool, o farmaci. Un momento di distrazione durante l'uso di un utensile pneumatico può causare lesioni gravi.

Istruzioni generali di sicurezza

Uso conforme

Questo utensile pneumatico deve essere utilizzato solo per rimuovere il materiale utilizzando dispositivi di taglio appropriati.

Non modificare l'utensile, eventuali protezioni o accessori salvo autorizzazione scritta da parte di Apex Tool Group, LLC.

AVVERTENZA



Qualsiasi abuso o uso scorretto del presente utensile o abrasivo può risultare estremamente pericoloso. L'abrasivo utilizzato con questo utensile non viene prodotto, né fornito da Apex Tool Group, LLC. Consultare e conformarsi alle procedura di sicurezza fornite dal produttore dell'abrasivo.

Lubrificazione del condotto dell'aria:

Articolo n.	Imballato	Designazione
540397	1 qt (0,94 litri)	Airlube 10W/NR-420LB DR
533485	1 gallone (3,78 litri)	Airlube 10W/NR-420LB DR

Condotta di alimentazione dell'aria:

Parametro	Descrizione
Tubo aria	Diametro interno minimo: 1/4" (6,35mm) Lunghezza massima: 8,0' (2,4 m)
Intervallo pressione di esercizio	Indice di prestazione a: 90 psi (6,2 bar)
Aria compressa	Qualità aria ai sensi della norma ISO 8573-1, classe qualità 2.4.3 L'aria compressa deve essere pulita e secca.

Smaltimento:



Per quanto riguarda i componenti del presente utensile e i loro imballaggi, seguire le linee guida locali in materia di smaltimento.

Avvertenze sui diritti:

Apex Tool Group, LLC si riserva il diritto di apportare delle modifiche al documento o al prodotto, di completarlo e/o di ottimizzarlo senza dare preavviso. Senza espressa approvazione di Apex Tool Group, LLC, questa documentazione non può essere riprodotta né completamente né in parte in qualsivoglia modo o riportata in un'altra lingua naturale o leggibile meccanicamente, oppure su un supporto dati elettronico, meccanico, ottico o di altro genere.

制造商:

Apex Tool Group, LLC
670 Industrial Drive
Lexington, South Carolina 29072, USA

进口商:

Apex Tool Group GmbH
Industriestraße 1
D-73463 Westhausen, Germany

有关本说明手册

本说明手册的原始语言为英语。本说明手册供操作和维护本设备的所有人员使用。

产品上的符号

使用本设备之前，确保您理解这些符号的含义。



阅读所有说明



在操作或维护本工具期间必须始终佩戴护目装置。



工具的操作或维护期间始终佩戴护耳设备。



通过CE认证

1 安全性

警告



指示会为人身安全和健康带来潜在危险的情况。如果忽视此警告，可能导致最严重的人身伤害。

小心



对人员健康或财产和环境可能有损害的状况。

转速检查

使用转速表每周或每隔200工作小时执行工具转速检查，确认其在90 psig供气压力下未超出工具额定转速。

个人防护装备

警告



使用气动工具工作时，应始终小心谨慎，注意自己正在做的事，并合理地操作。切勿在受到毒品、酒精或药物影响的情况下使用气动工具。使用气动工具时片刻的不专注也可能导致严重伤害。

一般安全说明

指定用途

该气动工具仅用于通过利用适当的切割装置去除材料。

除非获得Apex Tool Group, LLC的书面批准，否则不得对本工具、任何防护装置或附件进行改装。

警告



任何滥用或误用本工具或磨具的行为都是极度危险的。配合本工具使用的磨具并非由Apex Tool Group, LLC制造或供应。请参阅并遵守磨具制造商提供的安全守则。

供气管润滑:

部件号	已打包	说明
540397	1 夸脱 (0.94 升)	Airlube 10W/NR-420LB DR
533485	1 美制加仑 (3.78 升)	Airlube 10W/NR-420LB DR

空气供应管:

参数	描述
空气软管	最小内径: 1/4" (6.35mm) 最大长度: 8.0' (2.4 m)
工作压力范围	额定性能: 90 psi (6.2 bar)
压缩空气	空气质量依据为 ISO 8573-1, 质量等级为 2.4.3 压缩空气必须洁净、干燥。

处置:



遵守当地关于此工具所有组件及其包装的处置方针。

版权保护:

Apex Tool Group, LLC保留对本文档或产品进行修改、补充或完善的权利，恕不提前通知。未经Apex Tool Group, LLC明确允许，不得以电子、机械、视觉或其它任何方式或形式对本文档的全部或部分进行复制，也不得翻译成其它自然语言或机器可读语言或复制到数据载体上。

製造者:

Apex Tool Group, LLC
670 Industrial Drive
Lexington, South Carolina 29072, USA

輸入者:

Apex Tool Group GmbH
Industriestraße 1
D-73463 Westhausen, Germany

このマニュアルについて

このマニュアルの原文は英語です。このマニュアルは本製品の操作および保守を行うすべての人を対象とします。

製品上に表示される記号

本製品を使用する前に意味を確認してください。



すべての指示事項を読んでください。



この工具の操作または保守を行う際には必ず保護眼鏡を着用してください。



この工具の操作または保守を行う際には必ずイヤーマフを着用してください。



CE 適合

1 安全:

警告



人の健康・安全に危険を及ぼす可能性のある状況を示します。この警告に従わないと死亡または重傷事故のおそれがあります。

注意



軽傷または中程度の負傷あるいは物損・環境を損傷する危険がある状況を示します。

速度チェック

タコメータを用いて工具の回転速度を毎週、または使用 200 時間ごとにチェックし、90 psig での定格速度を超えていないことを確認してください。

個人用保護具

警告



空圧工具使用中は常に自身の動作に注意を向け、適切に行動してください。薬物、アルコールまたは医薬品の影響が残っている状態で空圧工具を使用してはなりません。空圧工具使用中の一瞬の不注意が重傷につながる可能性があります。

安全上の一般的注意事項

所定用途

この空気圧工具は、適切な切断装置を利用して材料を除去する目的でのみ使用してください。

→ Apex Tool Group, LLC の書面による許諾なく工具、ガード、アクセサリを改造することを禁じます。

警告



工具および研削材の誤った、あるいは不適切な使用は極めて危険です。Apex Tool Group, LLC はこの工具に使用する研削材の製造・販売を行っておりません。研削材メーカーの提供する安全指針を参照し、これに従ってください。

空気管潤滑油:

部品番号	梱包	出荷先
540397	0.94リットル	Airlube 10W/NR-420LB DR
533485	3.78リットル	Airlube 10W/NR-420LB DR

エアサプライ管:

パラメータ	説明
エアホース	最小内径: 6.35mm 最大長: 2.4 m
作業圧力範囲	性能定格: 90 psi (6.2 bar)
圧搾空気	ISO 8573-1による空気質、質クラス2.4.3 圧搾空気は清潔で乾燥している必要があります。

廃棄方法:



本ツールのすべての部品およびその梱包は、お住まいの地域の廃棄ガイドラインに従ってください。

著作権保護:

Apex Tool Group, LLC は本文書または本製品を予告なく改変、増補または改良する権利を留保します。Apex Tool Group, LLC の明示的な許諾なく本文書の全部または一部を何らかの方法・形態・形式で複製すること、他の自然言語または機械可読言語あるいは電子的・機械的・光学的データ担体に複写することを禁じます。

제조사:

Apex Tool Group, LLC
670 Industrial Drive
Lexington, South Carolina 29072, USA
수입자:
Apex Tool Group GmbH
Industriestraße 1
D-73463 Westhausen, Germany

사용 설명서 관련 정보

본 사용 설명서는 원래 영어로 작성되었습니다. 본 사용 설명서는 제품을 사용하고 유지보수하는 모든 사람을 대상으로 작성되었습니다.

제품상의 기호

제품을 사용하기 전에 다음 기호의 의미를 이해하고 숙지하시기 바랍니다.



모든 지침을 읽고 숙지하십시오.



이 공구를 사용하거나 유지보수하는 중에는 항상 보안경을 착용해야 합니다.



유지 보수 또는 이 도구를 사용하는 동안, 당신은 항상 귀 보호를 착용해야 합니다.



CE 규정 준수

1 안전:



경고 건강과 안전에 잠재적으로 위험한 상황을 나타냅니다. 이 경고를 준수하지 않으면 심각한 부상을 당하거나 사망에 이를 수 있습니다.



주의 피하지 않으면 경미한 부상이나 재산 및 환경 피해를 일으킬 수 있는 잠재적으로 위험한 상황을 나타냅니다.

속도 점검

속도계를 사용해 90 psig의 공구 정격 속도를 초과하지 않도록 매주 또는 200시간 작동 후마다 공구 속도를 점검하십시오.

개인 보호 장비



경고 공압 공구를 사용할 때는 항상 현재 작업에 집중하고 합리적으로 행동하십시오. 절대로 술이나 약을 복용한 상태로 공압 공구를 사용하지 마십시오. 공압 공구를 사용할 때는 한 순간의 부주의가 심각한 부상으로 이어질 수 있습니다.

일반 안전 지침

용도

이 공압식 공구는 적절한 절삭 장치를 사용하여 재료를 제거하는 데만 사용해야 합니다.

Apex Tool Group LLC의 서면 승인 없이 공구, 가드 또는 액세서리를 개조하지 마십시오.



경고 이 공구나 연마재를 오용 또는 남용하면 매우 위험한 상황에 처할 수 있습니다. 이 공구와 함께 사용하는 연마재는 Apex Tool Group, LLC에서 제조 또는 공급하지 않습니다. 연마재 제조사에서 제공하는 안전 지침을 확인하고 준수하십시오.

공기선 유통제:

부품 번호	포장	지정
540397	1쿼트 (0.94리터)	공기윤활유 10W/NR-420LB DR
533485	1 미국 갤런 (3.78리터)	공기윤활유 10W/NR-420LB DR

공기 공급선:

파라미터	설명
에어 호스	최소 내부 직경: 1/4" (6.35mm) 최대 길이 8.0' (2.4 m)
조작 압력 범위	성능 등급: 90 psi (620 kPa)
압축 공기	ISO 8573-1, quality class 2.4.3에 의거한 공기 품질 압축 공기는 반드시 깨끗하고 건조한 공기여야 합니다.

폐기:



이 공구와 패키징의 모든 구성품에 대해서는 현재의 폐기 가이드라인을 준수하십시오.

저작권 보호:

Apex Tool Group, LLC는 사전 예고 없이 본 사용 설명서나 제품을 수정, 보완 또는 개선할 수 있습니다. 본 사용 설명서의 전체 또는 일부를 어떤 방식이나 모양 또는 형태로 Apex Tool Group, LLC의 명시적인 허가 없이 전자적, 기계적, 광학적 또는 다른 방법으로 다른 자연어나 기계가 읽을 수 있는 언어 또는 데이터 이동 매체로 복제 또는 복사할 수 없습니다.

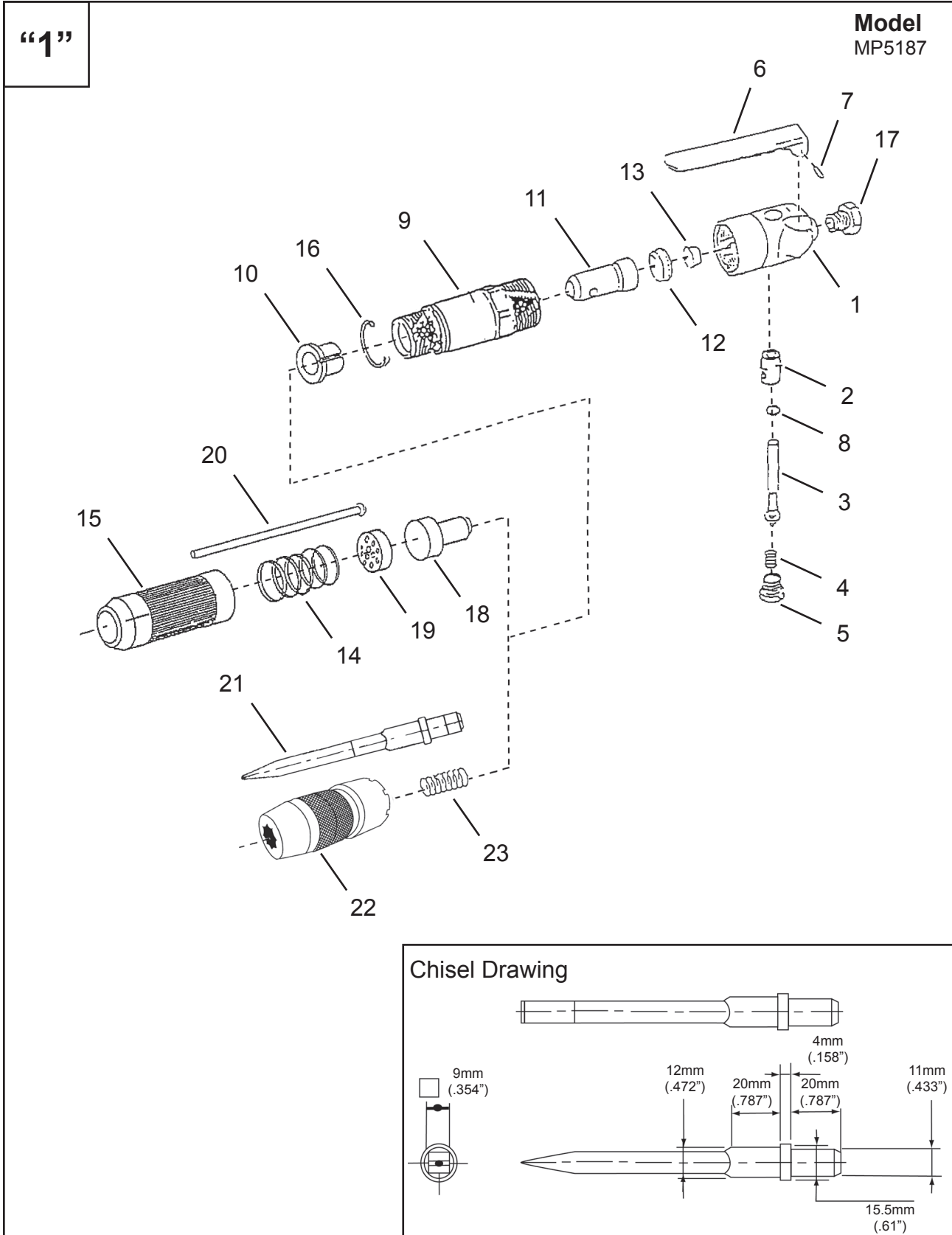

Illustration "1"

Ref	Number	#	X	EN	
				Description	
1	-----	1	K1		Cylinder Cap
2	-----	1	K1		Throttle Bushing
3	-----	1	K3		Throttle Valve
4	-----	1	K3		Spring
5	-----	1	K3		O-Ring
6	-----	1	K2		Throttle Lever
7	-----	1	K2		Spring Pin
8	-----	1	K3		O-Ring
9	71010400	1			Cylinder Body
10	71010500	1			Chisel Bushing
11	71010600	1			Piston
12	71010700	1			Cylinder Cover
13	71010800	1			Buffer
14	71010900	1			Needle Holder Spring
15	71011000	1			Needle Tube
16	-----	1	K5		Lock Ring
17	-----	1	K1		Air Inlet
18	71011200	1			Needle Driver
19	-----	1	K4		Needle Holder
20	-----	12	K4		Needle (3mm)
21	-----	1	K6		Chisel (9mm x 155mm)
22	-----	1	K7		Chisel Holder
23	-----	1	K7		Spring (16 x 34)
Repair Kits					
K1	71010000	1			Cylinder Kit Sub-Assembly
K2	71010100	1			Throttle Lever Kit
K3	71010200	1			Throttle Valve Kit
K4	71010300	1			Needle Kit (12 pieces)
K5	71011100	1			Lock Ring Kit (5 pieces)
K6	71011300	1			Chisel Kit (9mm x 155mm) (5 pieces)
K7	71011400	1			Chisel Conversion Kit

(#) Quantity

(X) Included in Parts Kit

Optional Scaler Accessories (not shown)

Number	EN	
	Description	
8913300	Carbon Steel Flat Tip Needle Kit (3mm x 7") (12 pieces)	
80074300	Chisel Tip Needle (3mm x 7")	
71010300	Needle Scaler Kit (3mm x 5" needle with holder) (12 needles)	

POWER TOOLS SALES & SERVICE CENTERS

Please note that all locations may not service all products.

Contact the nearest Cleco® Sales & Service Center for the appropriate facility to handle your service requirements.

 Sales Center

 Service Center

NORTH AMERICA | SOUTH AMERICA

Detroit, Michigan

Apex Tool Group
2630 Superior Court
Auburn Hills, MI 48236
Phone: +1 (248) 393-5644
Fax: +1 (248) 391-6295

Lexington, South Carolina

Apex Tool Group
670 Industrial Drive
Lexington, SC 29072
Phone: +1 (800) 845-5629
Phone: +1 (919) 387-0099
Fax: +1 (803) 358-7681

Mexico

Apex Tool Group
Vialidad El Pueblito #103
Parque Industrial Querétaro
Querétaro, QRO 76220
Mexico
Phone: +52 (442) 211 3800
Fax: +52 (800) 685 5560

Brazil

Apex Tool Group
Av. Liberdade, 4055
Zona Industrial Iporanga
Sorocaba, São Paulo
CEP# 18087-170
Brazil
Phone: +55 15 3238 3870
Fax: +55 15 3238 3938

EUROPE | MIDDLE EAST | AFRICA

England

Apex Tool Group GmbH
C/O Spline Gauges
Piccadilly, Tamworth
Staffordshire B78 2ER
United Kingdom
Phone: +44 1827 8727 71
Fax: +44 1827 8741 28

France

Apex Tool Group SAS
25 Avenue Maurice Chevalier - ZI
77330 Ozoir-La-Ferrière
France
Phone: +33 1 64 43 22 00
Fax: +33 1 64 43 17 17

Germany

Apex Tool Group GmbH
Industriestraße 1
73463 Westhausen
Germany
Phone: +49 (0) 73 63 81 0
Fax: +49 (0) 73 63 81 222

Hungary

Apex Tool Group
Hungária Kft.
Platánfa u. 2
9027 Győr
Hungary
Phone: +36 96 66 1383
Fax: +36 96 66 1135

ASIA PACIFIC

Australia

Apex Tool Group
519 Nurigong Street, Albury
NSW 2640
Australia
Phone: +61 2 6058 0300

China

Apex Power Tool Trading
(Shanghai) Co., Ltd.
2nd Floor, Area C
177 Bi Bo Road
Pu Dong New Area, Shanghai
China 201203 P.R.C.
Phone: +86 21 60880320
Fax: +86 21 60880298

India

Apex Power Tool India
Private Limited
Gala No. 1, Plot No. 5
S. No. 234, 235 & 245
Indialand Global
Industrial Park
Taluka-Mulsi, Phase I
Hinjawadi, Pune 411057
Maharashtra, India
Phone: +91 020 66761111

Japan

Apex Tool Group Japan
Korin-Kaikan 5F,
3-6-23 Shibakoen, Minato-Ku,
Tokyo 105-0011, JAPAN
Phone: +81-3-6450-1840
Fax: +81-3-6450-1841

Korea

Apex Tool Group Korea
#1503, Hibrand Living Bldg.,
215 Yangjae-dong,
Seocho-gu, Seoul 137-924,
Korea
Phone: +82-2-2155-0250
Fax: +82-2-2155-0252

Cleco®

Production Tools



PL16-5187-LG1

Cleco Production Tools

Phone: +1 (800) 845-5629
Phone: +1 (919) 387-0099
Fax: +1 (803) 358-7681
www.ClecoTools.com
www.ClecoTools.de